



RAM 1500

DT HURRICANE MOTOR 2025-on

PREDATOR & TORO FRONT BAR

IMPORTANT! – READ BEFORE INSTALLATION

- When installed in accordance with these instructions, the front protection bar does not affect the operation of the vehicles SRS airbags.
- This product must be installed exactly as per these instructions using only hardware supplied.
- Take a few moments to read instructions thoroughly before beginning work.
- In the event of damage to any bar component please contact OFFROAD ANIMAL to arrange repair/replacement of components.
- Do not use this product for any vehicle make or model other than that specified on these instructions.
- Do not remove labels from this product.
- This product and its fixings must not be modified in any way unless stated in these fitting instructions.
- The installation of this product is recommended for trained personnel.
- These instructions are correct at time of publication. OFFROAD ANIMAL cannot be held responsible for the impact of any changes subsequently made by the vehicle manufacturer. If you find something has changed, please contact us to let us know!
- During installation it is the duty of the installer to check correct operation/clearances of all components.
- If Instructions are to be printed for reference in the workshop, it is recommended that they are printed in colour, for best legibility.

GENERAL CARE AND MAINTENANCE

Use caution when cleaning with pressure washers, as they may compromise the product coating's integrity. Exercise care to avoid surface damage.

Only wash the product with a PH neutral car wash to prevent paint damage and discolouration.

Do not use acidic or alkaline based cleaning products.

Plastic parts may be maintained with silicone spray.

It is important to perform regular checks (pre/during/post trip or on an annual basis) on the installed product. More frequent checks may be required in extreme use cases. Checks include:

- Visual inspection for damage (eg. cracks, chips, dents etc.)
- Electrical wiring is not rubbing anything or worn out
- Bolts are torqued to correct specification (see torque guide below)

For touching up small stone chips, Offroad Animal recommends the following paint products:

- Dupli-Color Trim & Bumper Paint Black (TB101)
- VHT Hood, Bumper & Trim Paint Black (SP27)

BOLT TORQUE SETTINGS

Use the following bolt torques on all general fasteners, unless otherwise specified.

GENERAL FASTENERS	
Size	Torque Nm
M5	5 Nm
M6	9 Nm
M8	22 Nm
M10	44 Nm
M12	77 Nm

Use the following bolt torques on all structural front bar mount and tow point fasteners, and rear towbar fasteners, unless otherwise specified.

FRONT BAR MOUNTS AND TOW POINTS + REAR TOWBAR	
Size	Torque Nm
M10	57 Nm
M12	100 Nm
M14	164 Nm
M16	248 Nm







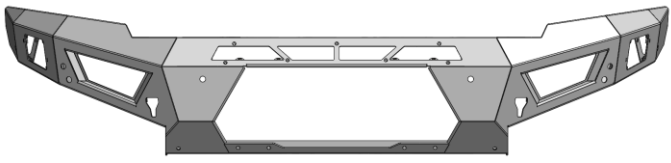
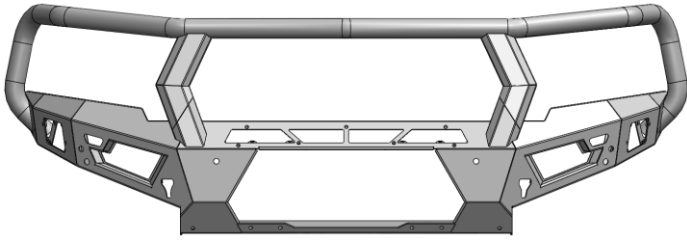
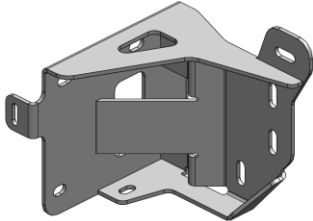
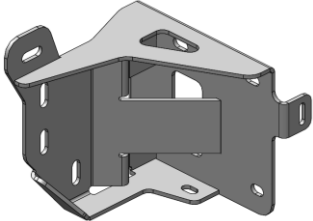
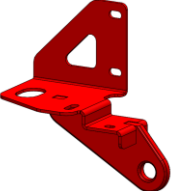
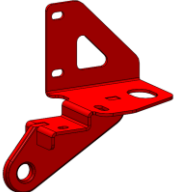

Always use a torque wrench to set correct torque settings. Ensure torque wrench is set to Nm unit of measurement. Otherwise perform conversion to lb-ft.

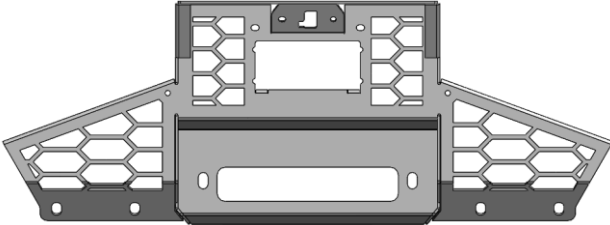



PARTS LISTING

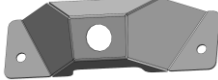
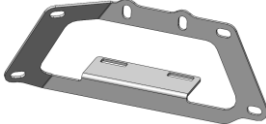
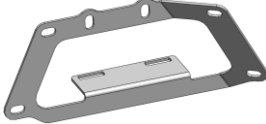

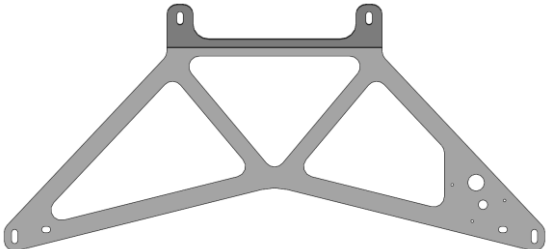



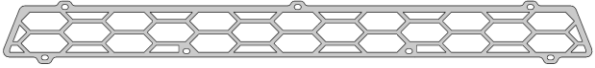

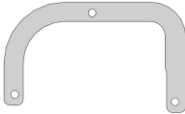
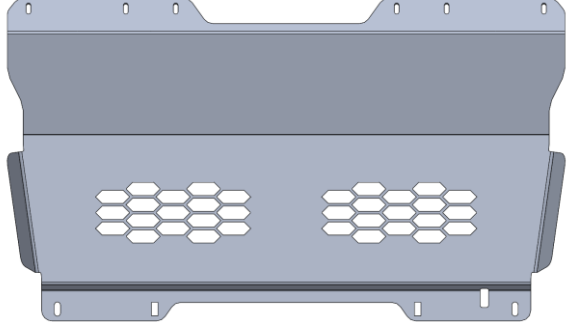
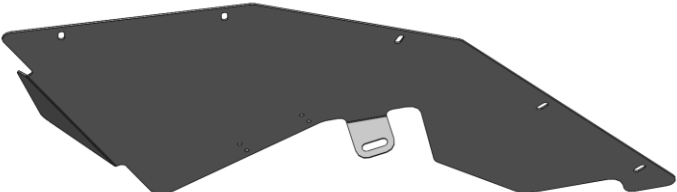
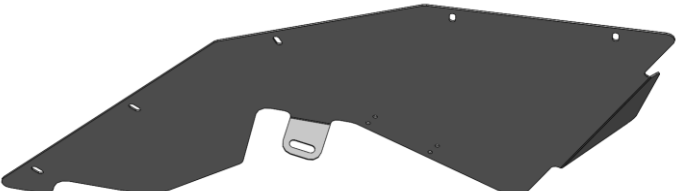
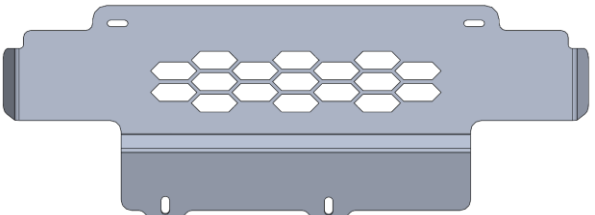
IMPORTANT: Check all parts are present before beginning work! Contact OFFROAD ANIMAL if something is missing.

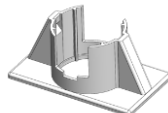

Main Parts – In the Box

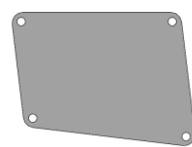
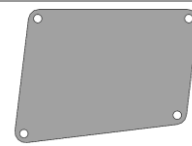

Qty	Part Number	Description	Image
1	FB-R15-DT-25-PR-ASM1	RAM 1500 DT MY25 Hurricane Predator Bar Weldment	
OR			
1	FB-R15-DT-25-TOR-ASM1	RAM 1500 DT MY25 Hurricane Toro Bar Weldment	
1	FB-R15-DT-25-PR-ASM2R	RAM 1500 DT MY25 Hurricane Impact Assembly RH	
1	FB-R15-DT-25-PR-ASM2L	RAM 1500 DT MY25 Hurricane Impact Assembly LH	
1	FB-R15-DT-25-PR-ASM3R	RAM 1500 DT MY25 Hurricane Tow Point RH	
1	FB-R15-DT-25-PR-ASM3L	RAM 1500 DT MY25 Hurricane Tow Point LH	

1	FB-R15-DT-25-PR-ASM4	RAM 1500 DT MY25 Hurricane Mesh Fairlead	
1	B-0821	WL ACC Radar Bracket	
2	B-1406	LC100/105 Pan Brace	
1	B-1708R	DT Hurricane Type A Fog Light Bracket RH	
1	B-1708L	DT Hurricane Type A Fog Light Bracket LH	
1	B-1709	DT Hurricane Camera Clamp	
1	B-1710	DT Hurricane Camera Housing	
1	B-1713R	DT Hurricane FCTA Radar Mount Base RH	
1	B-1713L	DT Hurricane FCTA Radar Mount Base LH	
1	B-1714R	DT Hurricane FCTA Radar Mount Clamp RH	
1	B-1714L	DT Hurricane FCTA Radar Mount Clamp LH	
1	B-1715	DT Hurricane Winch Strap	

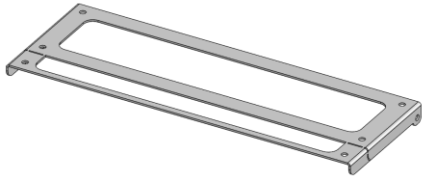
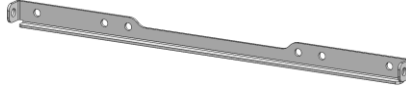
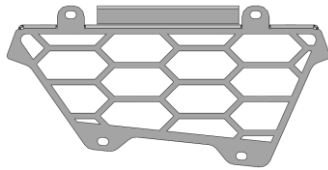
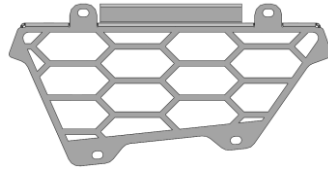
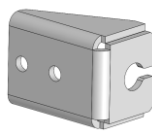
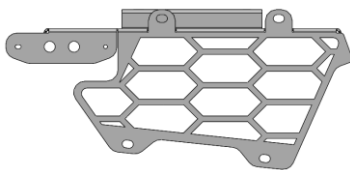
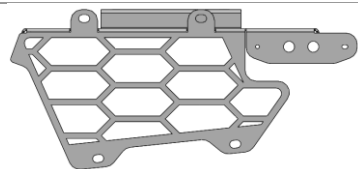
1	B-1716R	DT Hurricane Bash Plate Mount RH	
1	B-1716L	DT Hurricane Bash Plate Mount LH	
1	P-0488	BYD Shark 6 Lightbar Mesh Infill	
2	P-0507	DT Hurricane Tow Point Spreader Plate	
1	P-0509	DT Hurricane Shutter Motor Relocation Plate	
1	P-0512	DT Hurricane Active Air Dam Motor Spacer Plate	
1	U-0122	DT Hurricane Centre Bash Plate	
1	U-0123R	DT Hurricane Side Underpanel RH	
1	U-0123L	DT Hurricane Side Underpanel LH	
1	U-0124	DT Hurricane Lower Bash Plate	

1	CPHP029	Plastic Hole Insert, 17.4MM, Black, Tigerlink Hardware CPHP029	
2	CPHP032	Plastic Hole Insert, 20MM, Black, Tigerlink Hardware CPHP03	
6	F-0030	Parking Sensor Holder - Universal, Flat	
2	F-0037	Narva Model 2 Marker Lamp Retaining Ring	
1	FB-R15-DT-25-PR-ADRCP	ADR Compliance Plate RAM 1500 DT MY25 Hurricane	
8	Fir Tree Clip 4.5mm Hole	Fine-rib push-in rivet, WURTH 0500827023	
1	N-0007	WL ACC Radar Cover Panel	
1	N-0024R	DT Hurricane FCTA Radar Cover RH	
1	N-0024L	DT Hurricane FCTA Radar Cover LH	
1	OFA-LOGO	Offroad Animal Metal Logo	
1	PSE14-4	Parking Sensor Extension PSE14 - 4 Pack	N/A
2	PWS-TOP-775	Pinch Weld PWS51T - Top Bulb Seal 775mm	N/A

1	TK-COM-PSEN-6	Tape Kit - 6 Sensor Universal	N/A
1	TK-FB-FRA-NG-22	Tape Kit - NG Ranger - 3M 5952 2x 100x6mm	N/A
NUMBER PLATE FLIP ASSEMBLY (NPF-COM-LGE-ASM0)			
1	B-1446	Number Plate Flip - Large	
1	B-1458	Number Plate Flip Base	
PREDATOR ONLY			
1	M-0077R	DT Hurricane Predator Wing Mesh RH	
1	M-0077L	DT Hurricane Predator Wing Mesh LH	
TORO ONLY			
1	B-0649	Toro Antenna Bracket - 90 Degree Tall	
1	M-0078R	DT Hurricane Toro Wing Mesh RH	
1	M-0078L	DT Hurricane Toro Wing Mesh LH	
1	11CAT1M-2	LED Autolamps 11CAT1M-2 Front Indicator - Twin Blister Pack	
1	LM-R15-DT-25-IND	RAM Toro Indicator Piggy Back Harness – Twin Pack	N/A

LARAMIE SPORT AND EXPRESS BLACK EDITION ONLY			
2	90222BL	Narva 90222BL Model 2 Front Marker Lamp	
OPTIONAL EXTRAS			
1	CNECT- HIGHBEAM	CanM8 CAN Bus High Beam Signal Interface	
1	RCAM1	RCAM1 Universal Camera Extension Harness, 100cm	

PREDATOR Fasteners – Contained in Small Parts Kit Bag

Qty	Part Number	Description
3	M4X25 CAP SCREW	CAP SCREW, M4X25X0.7 GR12.9 ZP
2	M4X50 CAP SCREW	CAP SCREW, M4X50X0.7 GR12.9 ZP
1	M4X65 CAP SCREW	CAP SCREW, M4X65X0.7 GR12.9 ZP
5	M4 FLAT WASHER	Flat Washer M4, 8mmODx0.8mm
6	M4 FLANGE NUT	Flange Nut, M4
22	M6 X 12 HEX	M6X12 HEX BOLT, ZP, 8.8
7	M6 X 12 CSK BZP	SCREW, COUNTERSUNK CAP, M6X12X1 Black ZP
32	M6x16 BHCS BLACK ZINC	SCREW, BUTTON HEAD CAP, M6X16X1 GR12.9, ISO4042 ZnNi BLACK PASSIVATED FINISH
22	M6 FLAT WASHER	M6 Flat Washer, 12x6.1x1
32	M6 FLAT WASHER BLACK ZINC	M6 Flat Washer, 12x6.1x1, ISO4042 ZnNi BLACK PASSIVATED FINISH
39	M6 FLANGE NUT	Flange Nut, M6x1 G8.8 ZP
10	M6CN3MM	CAGE NUT M6x2.6-3.5
6	M8 X 20 HEX	Bolt Hex, M8X20x1.25, GR8.8 ZP
2	M8 X 20 BHCS	SCREW, BUTTON HEAD CAP, M8X20X1.25 GR12.9 ZP
2	M8 X 16 BHCS BZP	SCREW, BUTTON HEAD CAP, M8X16X1.25 GR12.9, ISO4042 ZnNi BLACK PASSIVATED FINISH
8	M8 X 30 BHCS BLACK ZINC	SCREW, BUTTON HEAD CAP, M8X30X1.25, ISO4042 ZnNi BLACK PASSIVATED FINISH
8	M8 HD FLAT WASHER	M8 FLAT WASHER - High Tensile 19x8x1.9mm
10	M8 HD FLAT WASHER - BZP	M8 FLAT WASHER - High Tensile 19x8x2mm, ISO4042 ZnNi BLACK PASSIVATED FINISH
6	M8 FLANGE NUT	Flange Nut, M8x1.25 G8.8 ZP
2	M8 Cage nut	NUT, CAGE, M8X1.25 ZINC PLATE
4	M10 x 30	Bolt Hex, M10X30x[1.5], GR8.8 ZP
4	M10X30 BHCS	SCREW, BUTTON HEAD CAP, M10X30X1.5 GR12.9 ZP
8	M10 FW LHD	WASHER, FLAT M10X28.5X2.5
4	M10 FLANGE NUT	Flange Nut, M10x1.5 G8.8 ZP
24	M12X30	Bolt Hex, M12X30x1.75, GR8.8 ZP
26	M12 FW LHD	M12 FW Large Heavy Duty
20	M12 FLANGE NUT	Flange Nut, M12x1.75 G8.8 ZP
2	M12 Nyloc nut	M12 NYLOC NUT
1	P-0510	M4 Washer Plate, 16mm OD x 1.2 T
2	T-0096	P702 F-150 Intercooler Active Shutter Motor Spacer 15mm
2	T-0163	Crush Tube 11mm L, 10mm OD x 1.6 WT
2	NP-COM-M12-30-ASM0	M12 NUT PLATE SHORT, 30MM STEM

TORO Fasteners – Contained in Small Parts Kit Bag

Qty	Part Number	Description
4	M3X12 PAN	SCREW, PAN HEAD PHILLIPS, M3X12X0.5 GR4.6 ZP
4	M3 FLAT WASHER	Flat Washer M3, 7mmODx0.5mm T
4	M3 NUT	Hex Nut, M3x0.5 G48.8 ZP
3	M4X25 CAP SCREW	CAP SCREW, M4X25X0.7 GR12.9 ZP
2	M4X50 CAP SCREW	CAP SCREW, M4X50X0.7 GR12.9 ZP
1	M4X65 CAP SCREW	CAP SCREW, M4X65X0.7 GR12.9 ZP
5	M4 FLAT WASHER	Flat Washer M4, 8mmODx0.8mm
6	M4 FLANGE NUT	Flange Nut, M4
22	M6 X 12 HEX	M6X12 HEX BOLT, ZP, 8.8
7	M6 X 12 CSK BZP	SCREW, COUNTERSUNK CAP, M6X12X1 Black ZP
32	M6x16 BHCS BLACK ZINC	SCREW, BUTTON HEAD CAP, M6X16X1 GR12.9, ISO4042 ZnNi BLACK PASSIVATED FINISH
22	M6 FLAT WASHER	M6 Flat Washer, 12x6.1x1
32	M6 FLAT WASHER BLACK ZINC	M6 Flat Washer, 12x6.1x1, ISO4042 ZnNi BLACK PASSIVATED FINISH
39	M6 FLANGE NUT	Flange Nut, M6x1 G8.8 ZP
10	M6CN3MM	CAGE NUT M6x2.6-3.5
6	M8 X 20 HEX	Bolt Hex, M8X20x1.25, GR8.8 ZP
2	M8 X 20 BHCS	SCREW, BUTTON HEAD CAP, M8X20X1.25 GR12.9 ZP
2	M8 X 16 BHCS BZP	SCREW, BUTTON HEAD CAP, M8X16X1.25 GR12.9, ISO4042 ZnNi BLACK PASSIVATED FINISH
12	M8 X 30 BHCS BLACK ZINC	SCREW, BUTTON HEAD CAP, M8X30X1.25, ISO4042 ZnNi BLACK PASSIVATED FINISH
8	M8 HD FLAT WASHER	M8 FLAT WASHER - High Tensile 19x8x1.9mm
14	M8 HD FLAT WASHER - BZP	M8 FLAT WASHER - High Tensile 19x8x2mm, ISO4042 ZnNi BLACK PASSIVATED FINISH
6	M8 FLANGE NUT	Flange Nut, M8x1.25 G8.8 ZP
2	M8 Cage nut	NUT, CAGE, M8X1.25 ZINC PLATE
4	M10 x 30	Bolt Hex, M10X30x[1.5], GR8.8 ZP
4	M10X30 BHCS	SCREW, BUTTON HEAD CAP, M10X30X1.5 GR12.9 ZP
8	M10 FW LHD	WASHER, FLAT M10X28.5X2.5
4	M10 FLANGE NUT	Flange Nut, M10x1.5 G8.8 ZP
24	M12X30	Bolt Hex, M12X30x1.75, GR8.8 ZP
26	M12 FW LHD	M12 FW Large Heavy Duty
20	M12 FLANGE NUT	Flange Nut, M12x1.75 G8.8 ZP
2	M12 Nyloc nut	M12 NYLOC NUT
1	P-0510	M4 Washer Plate, 16mm OD x 1.2 T
2	T-0096	P702 F-150 Intercooler Active Shutter Motor Spacer 15mm
2	T-0163	Crush Tube 11mm L, 10mm OD x 1.6 WT
2	NP-COM-M12-30-ASM0	M12 NUT PLATE SHORT, 30MM STEM

NUMBER PLATE FLIP Fasteners – Contained in Number Plate Flip Kit

Qty	Part Number	Description
4	M6x12 BHCS BLACK ZINC	SCREW, BUTTON HEAD CAP, M6X12X1 GR12.9, ISO4042 ZnNi BLACK PASSIVATED FINISH
4	M6x16 BHCS BLACK ZINC	SCREW, BUTTON HEAD CAP, M6X16X1 GR12.9, ISO4042 ZnNi BLACK PASSIVATED FINISH
10	M6 FLAT WASHER BLACK ZINC	M6 Flat Washer, 12x6.1x1, ISO4042 ZnNi BLACK PASSIVATED FINISH
6	M6 FLANGE NUT	Flange Nut, M6x1 G8.8 ZP
2	M6 NYLON WASHER	Nylon Flat Washer, M6x12x1mm
2	M6 NYLOC	NYLOC SELF LOCKING NUT, ST STL A2 ISO

TOOLS REQUIRED

The following tools will be required to install the product.

Hand Tools	Power Tools	Workshop Equipment
Metric Socket Set 5.5-21mm	Electric/Air Impact Driver (Optional)	Panel Stand or Soft Blanket
Socket Extension Bar	Air Hacksaw or Jigsaw or Multi-tool	Lifting Trolley
Metric Spanner Set 5.5-21mm	Angle Grinder	Isopropyl Alcohol
Hex (Allen) Key Set 3-6mm	Soldering Iron	Clean Workshop Rag
Torx Bit Set T10-T40	Electric drill	Marker Pen
Trim Removal Tool		Measuring Tape
Flat Blade Screwdriver Set		Ruler
Phillips Head Screwdriver Set		Masking Tape
Plastic Auto Trim Tool		Black Spray Paint
Utility Knife		Cable Ties
Side Cutters		Solder
Hammer		Heat shrink
4.0-4.5mm Drill Bit Set		Electrical tape
Deburring Tool		Sikaflex adhesive
Wire Strippers		

WORKSHOP SAFETY

It is the responsibility of the installer to always complete works in a safe manner. Make sure the following safety equipment is available and precautions are observed whilst fitting this product.

<p>Hearing Protection</p> 	<p>Always wear ear protection when using power tools.</p>
<p>Eye Protection</p> 	<p>Ensure eye protection is always worn when cutting or drilling.</p>
<p>Manual Handling</p> 	<p>Do not attempt to lift bar assemblies or rock sliders on your own.</p> <p>Always use two people to lift or use mechanical Lifting aid such as hydraulic lifting trolley.</p>
<p>Vehicle Support</p> 	<p>Always ensure vehicle is properly supported when working on it. Do not attempt to fit products whilst suspension work is being carried out. Do not work under a vehicle supported only by a jack.</p>



WARNING:

Do not attempt to turn on and move the vehicle while the front radar/s, camera, air guide motors and parking sensors are disconnected. Doing so may cause DTC error codes that can only be rectified by the dealer.

1. Remove 2x screws holding front number plate with a Phillips head screwdriver and set aside.

TOOLS REQUIRED

Phillips head screwdriver

FASTENERS

2x screws (discard)



2. Remove 3x 8mm hex bolts securing the inner guard to the back edge of the bumper, per side.

TOOLS REQUIRED

8mm socket/spanner

FASTENERS

6x 8mm hex bolts

Discard



- 3. Remove 2x 8mm hex bolts securing the inner guard to the chassis, per side.
- 4. Remove the plastic inner guard on each side.

TOOLS REQUIRED

8mm socket/spanner

FASTENERS

4x 8mm hex bolts

Discard



- Remove 9x 8mm hex screws securing each flare to the wheel arch liner.

TOOLS REQUIRED

8mm socket/spanner

FASTENERS

9x 8mm hex bolts

Retain for re-fitment

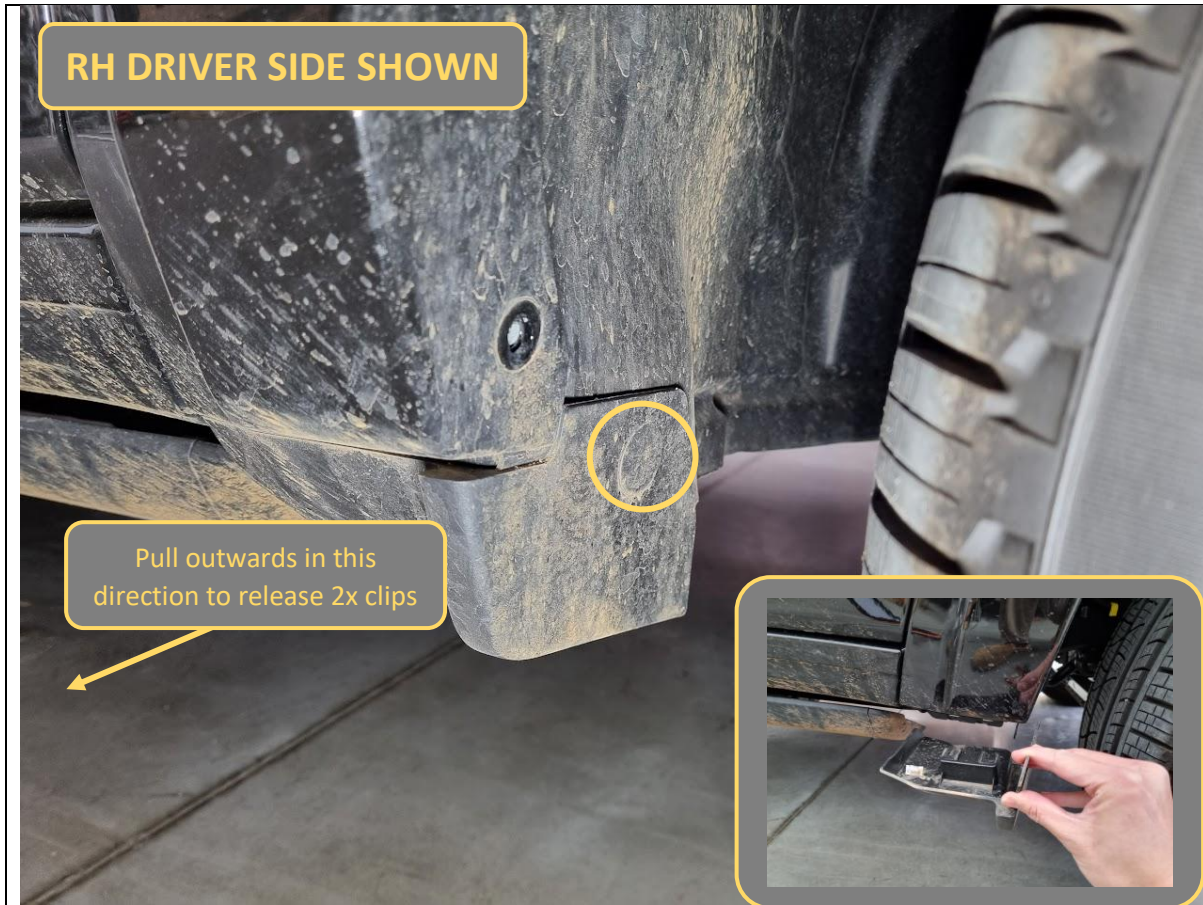

6. Remove 1x Christmas tree clip holding each mudflap, then pull outwards to release 2x plastic clips holding the mudflap to the body.

TOOLS REQUIRED

Trim removal tool

FASTENERS

2x Christmas tree clips

Retain for re-fitment



7. Locate and remove 3x Christmas tree clips and 2x 8mm hex screws holding each wheel arch liner, then remove wheel arch liner and set aside.

TOOLS REQUIRED

Trim removal tool
8mm socket/spanner

FASTENERS

6x Christmas tree clips
4x 8mm hex screws

Retain for re-fitment

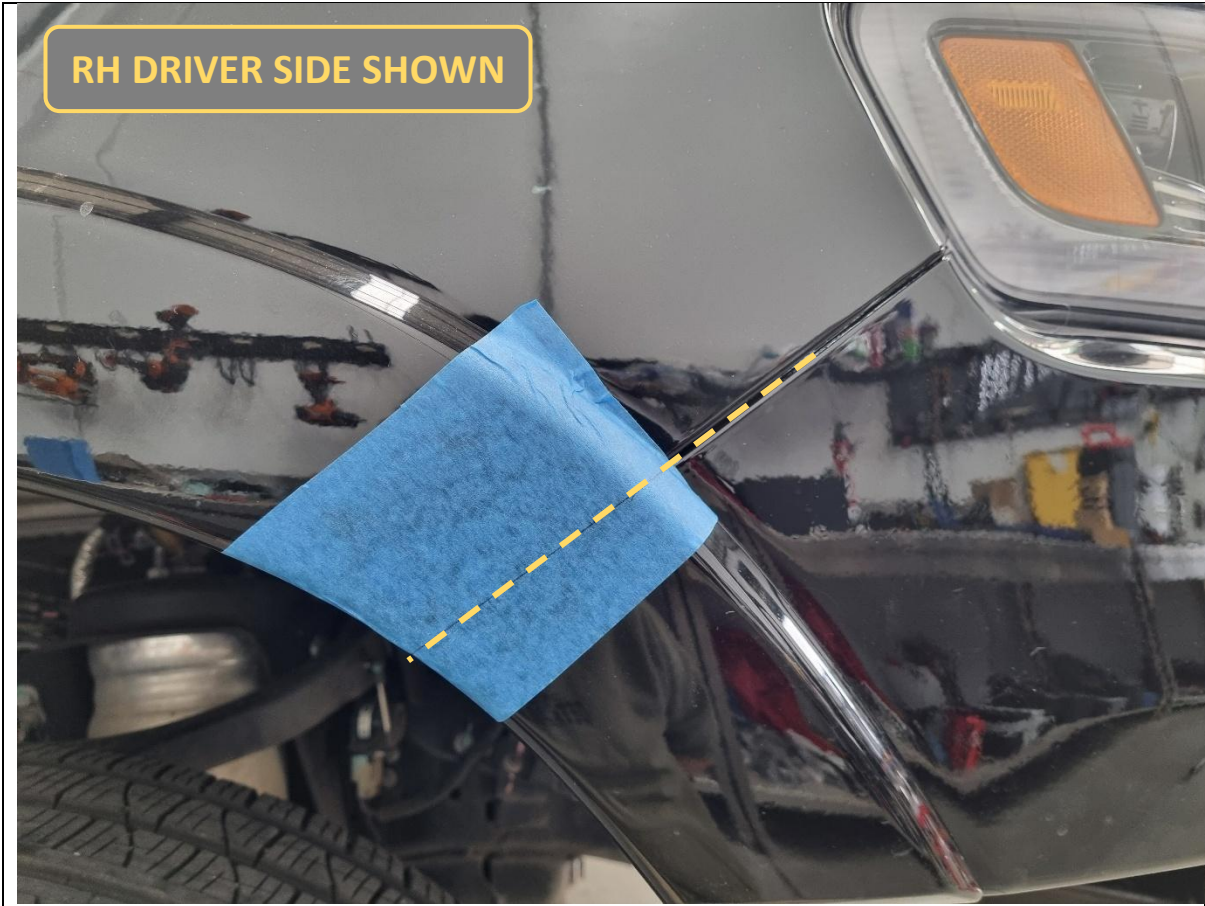

8. Apply masking tape to the flare at the quarter panel join, then mark a straight cut line on the flare, in line with the quarter panel.

TOOLS REQUIRED

Masking tape
Marker pen
Ruler

FASTENERS

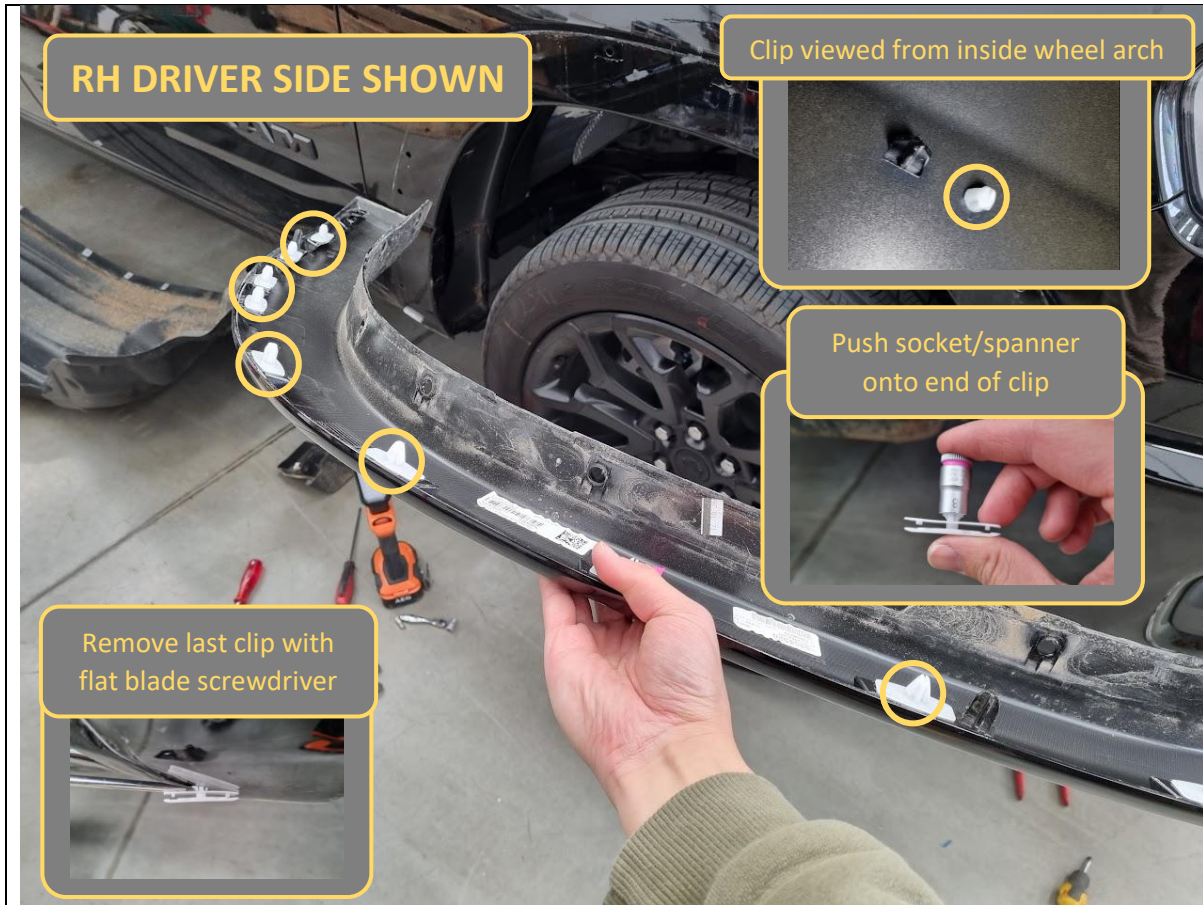

9. Reach inside the wheel arch with an 8mm socket/spanner, and use it to help release 13x flare clips.

The last clip near the door is difficult to access from the inside. Instead, you can carefully pull/wiggle the flare upwards and rearwards to separate the clip from the flare. Then you can finally remove the clip from the quarter panel afterwards with a flat blade screwdriver.

10. Pull outwards on the flares to fully release them from the car body. Set them aside for trimming later.

TOOLS REQUIRED

8mm socket/spanner
Flat blade screwdriver

FASTENERS

26x flare clips
Retain clipped to flare

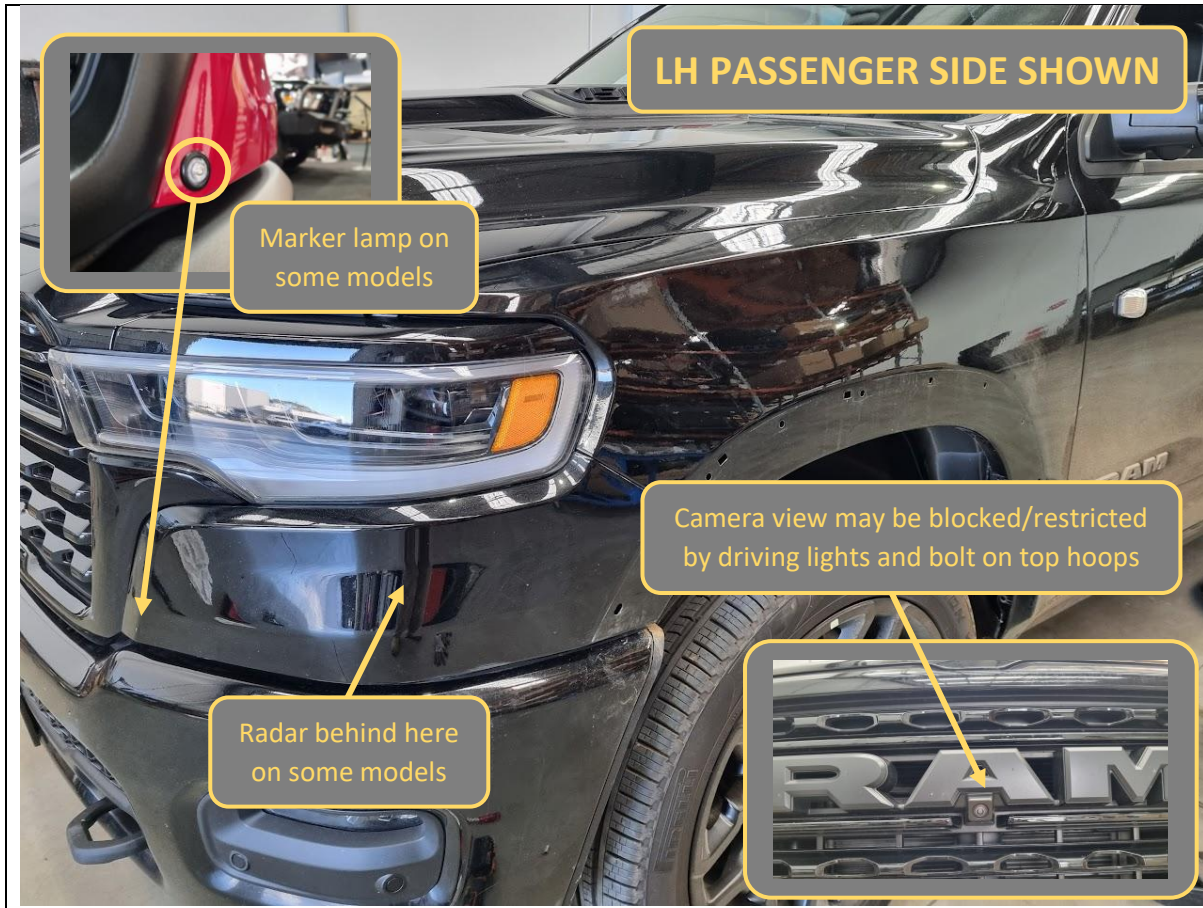

The front camera can be relocated into the bar for unobstructed view. This is recommended if the bar is fitted with driving lights or bolt on top hoops. To do this, the grille and plastic bumperettes under the headlights need to be removed.

On 'Limited' models, there is an 'Intersection Collision Assist System' radar hidden inside each plastic bumperette, which must unplugged/removed before the steel bumper is removed.

On 'Rebel' models, there is a marker lamp that must be removed and relocated into the bullbar.

The plastic bumperette requires cutting for fitting the bullbar. Removal is outlined in next steps.

TOOLS REQUIRED

FASTENERS

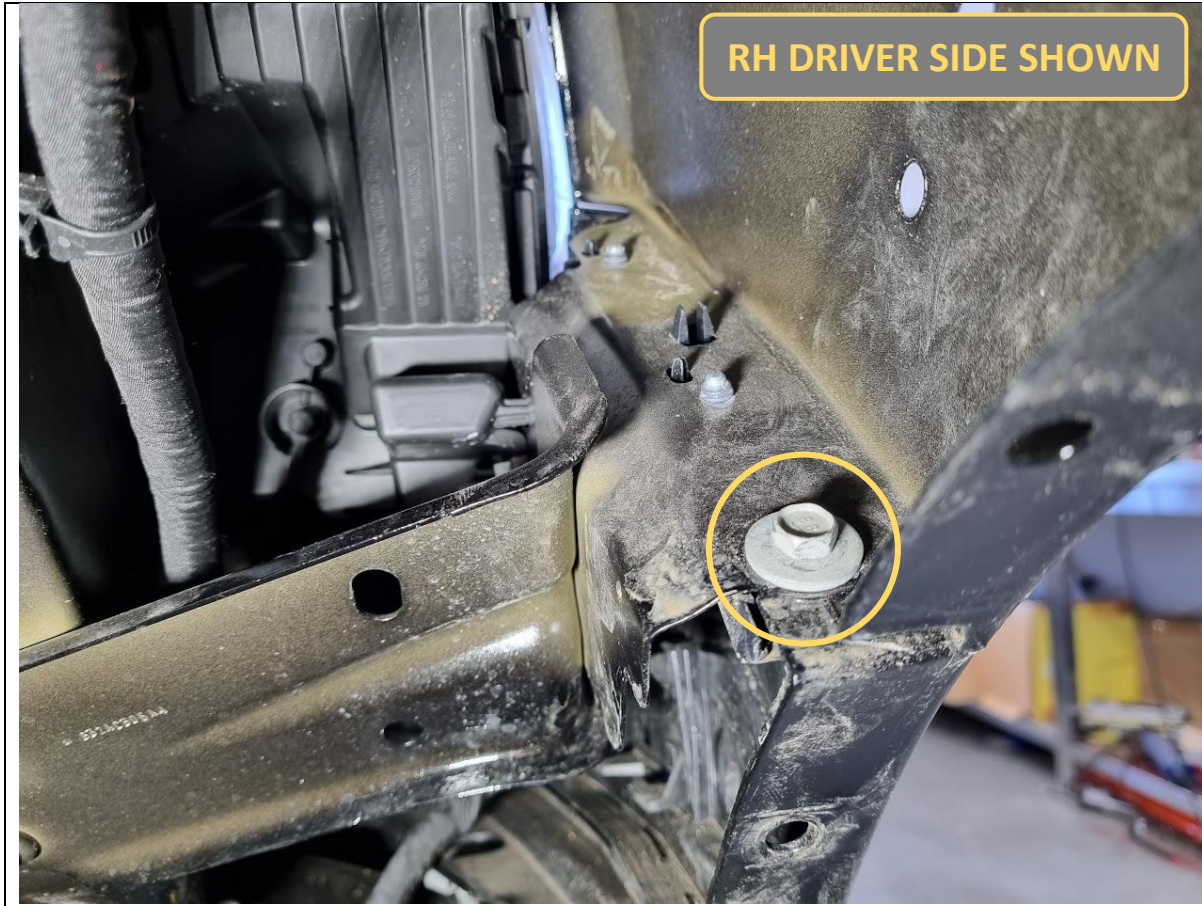

11. Reach in from the wheel arch and remove 1x 10mm hex bolt securing each plastic bumperette to the quarter panel.

TOOLS REQUIRED

10mm spanner

FASTENERS

2x 10mm hex bolt
Retain for re-fitment

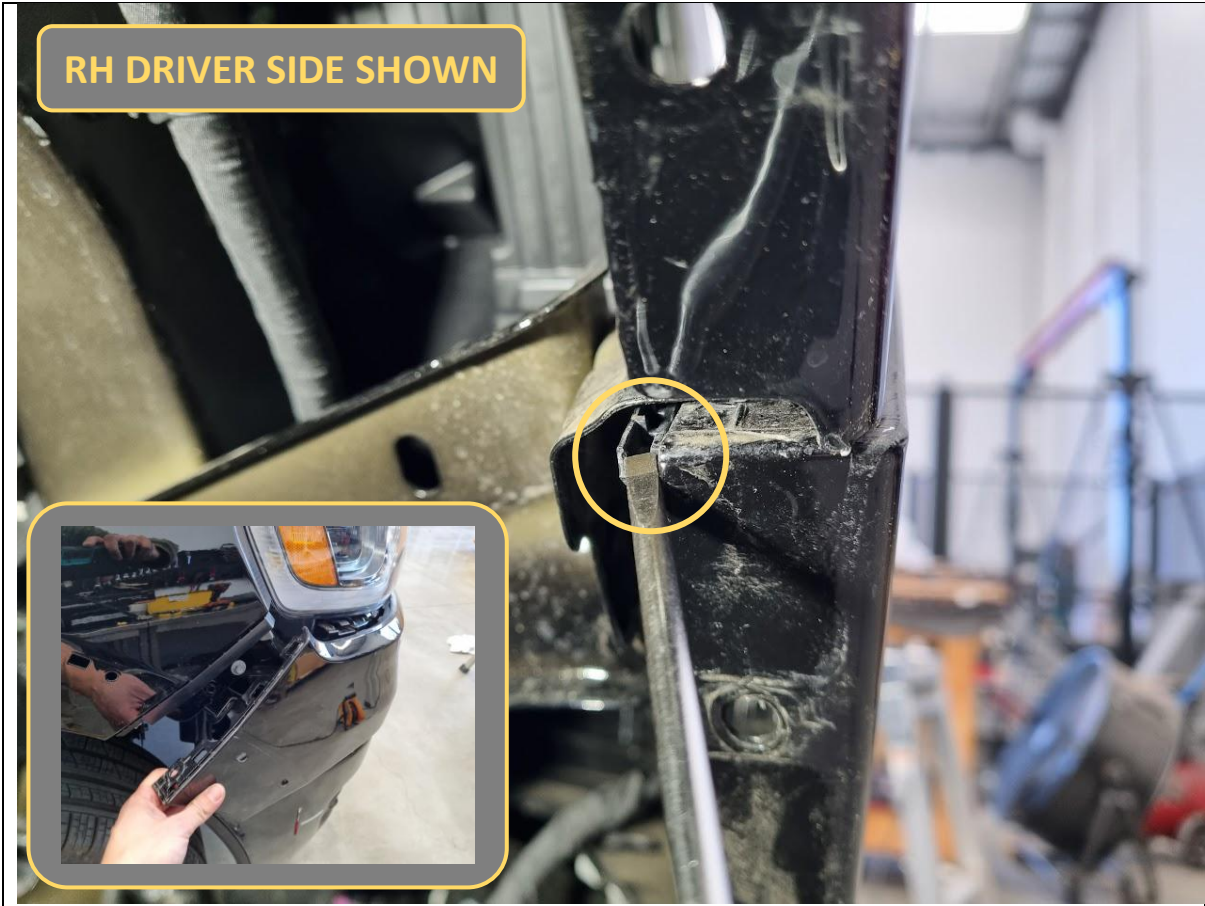

RH DRIVER SIDE SHOWN

12. Next to where the bolt was is a plastic tab. Push down on it with a flat blade screwdriver to release it, then pull the bumperette outwards from the outer corner.

TOOLS REQUIRED

Flat blade screwdriver

FASTENERS



13. Work along the top edge of the bumperette until you get to the grille. Here there are 3x clips that need to be released. A firm tug outwards, or using a small flat blade screwdriver on the inside, will release these clips.

It is also advised to use masking tape to protect the paint on the bumperette/grille if prying with a screwdriver.

TOOLS REQUIRED

Small flat blade screwdriver
Masking tape

FASTENERS

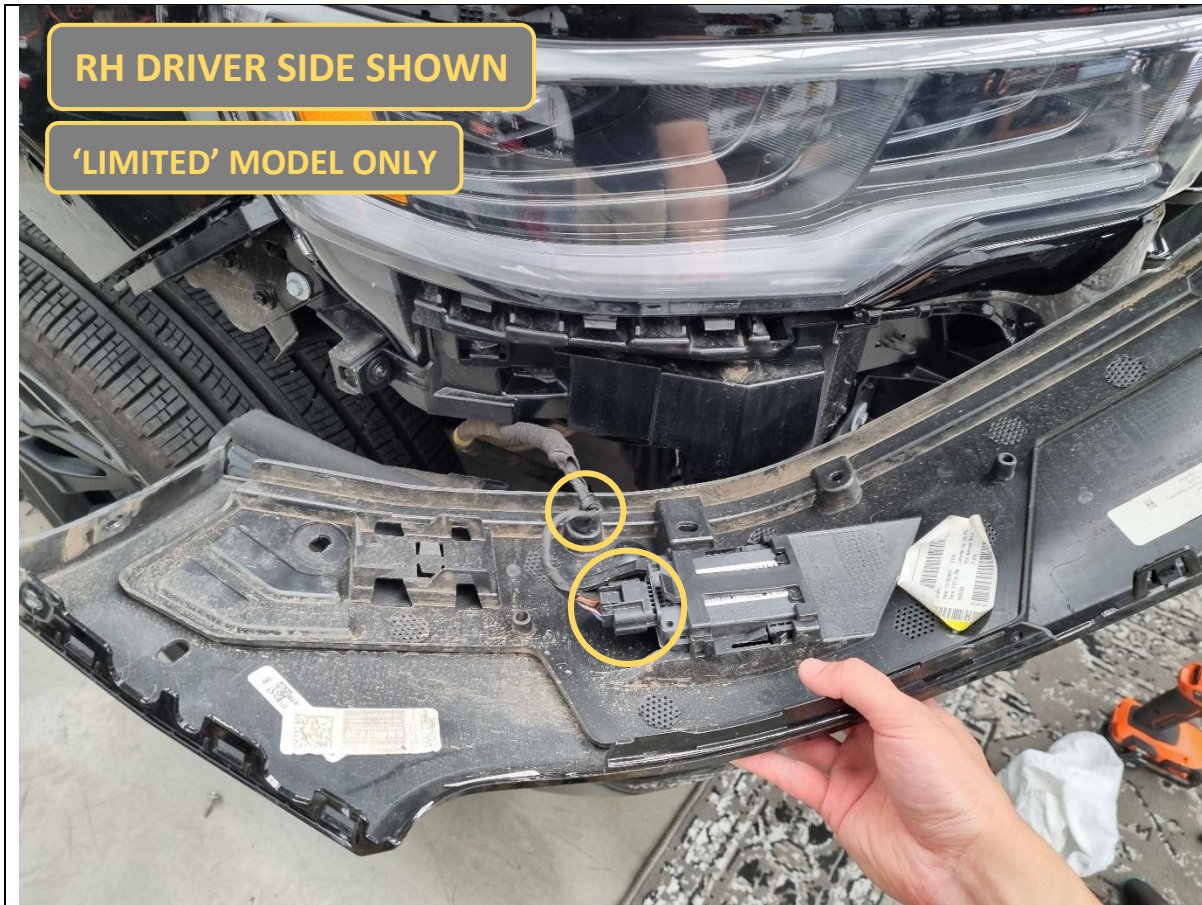

- 14. **'Limited' models only.** With the bumperette separated from the body, unplug the intersection collision assist system radar on the inside.
- 15. Also unclip the harness from the inside of the bumperette, using a trim tool or flat blade screwdriver to assist.

TOOLS REQUIRED

Trim tool
or
Flat blade screwdriver

FASTENERS



16. **'Rebel' models only.** With the bumperette separated from the body, remove the marker lamps and set aside.

The lamp should be fitted with a rubber grommet, so you should be able to push it out the front face of the bumperette. Keep the lamp and grommet.

The wires may need to be snipped and soldered back together later.

TOOLS REQUIRED

FASTENERS

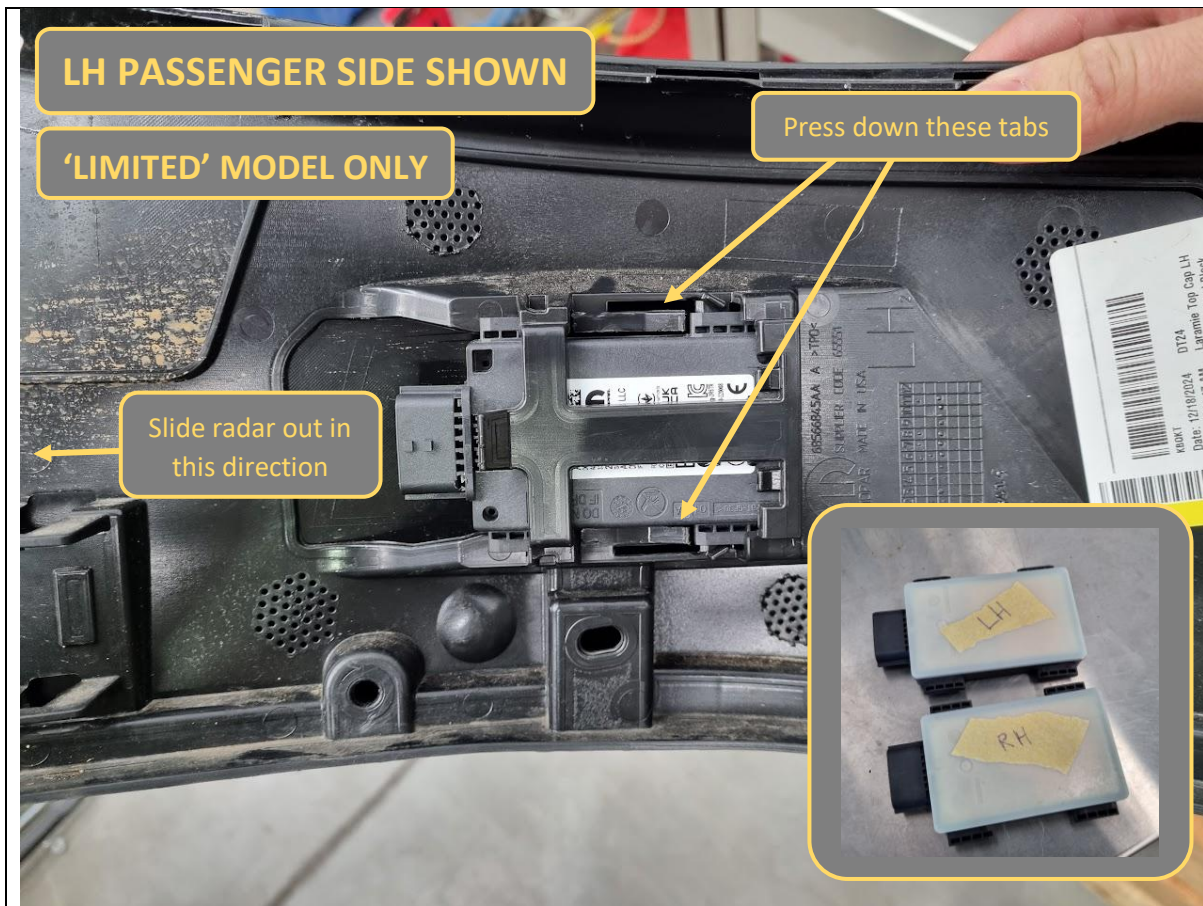

17. **All models.** Remove the bumperettes and set them aside.
18. **'Limited' models only.** Unclip the intersection collision assist system radars from the bumperette, label them LH and RH, and set them aside in a safe place.

Warning: Do not drop or impact the radars.

TOOLS REQUIRED

FASTENERS

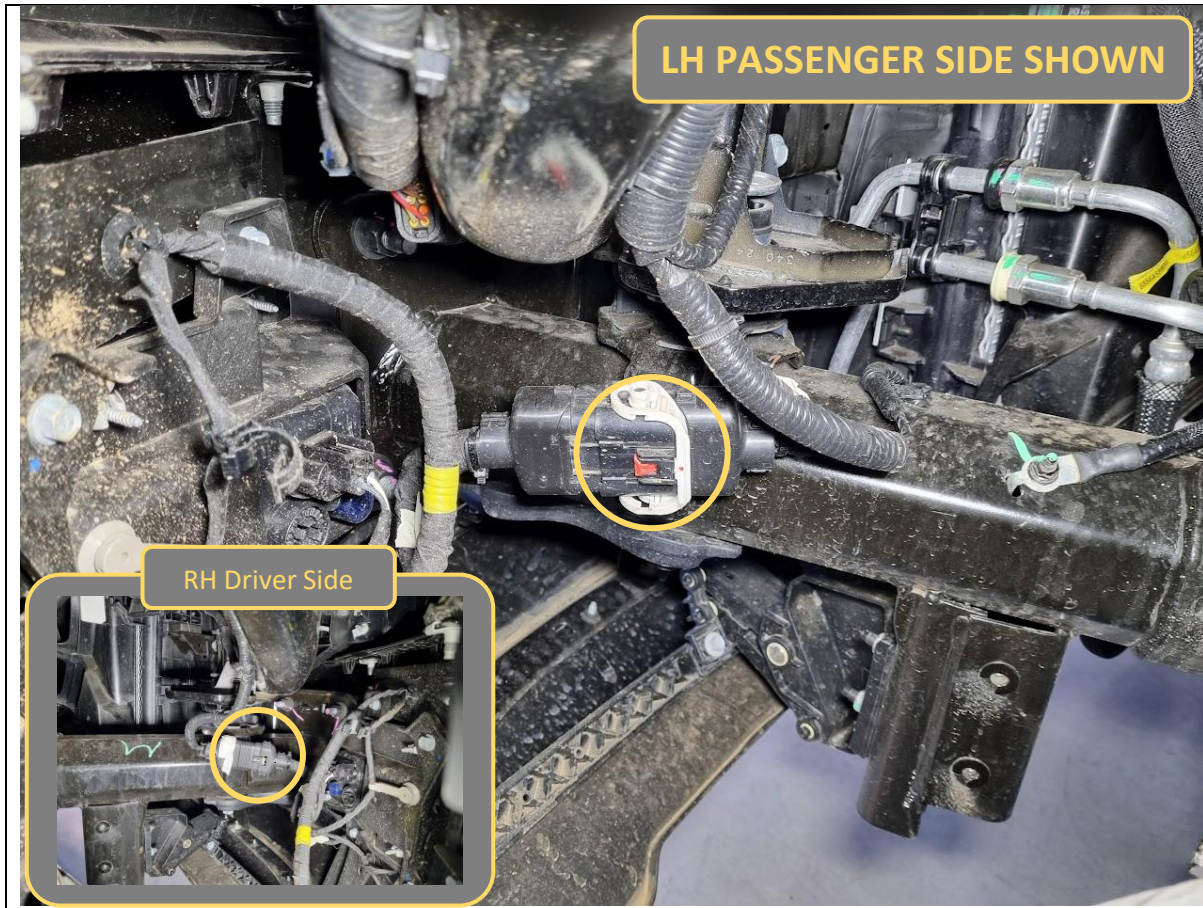

19. Reach in behind the bumper and disconnect the bumper harness on both the LH and RH chassis rail.

The LH connector is a lever style, press down on the red tab then pull on the lever to disconnect.

The RH connector is a normal style, press down on the tab to disconnect.

TOOLS REQUIRED

FASTENERS

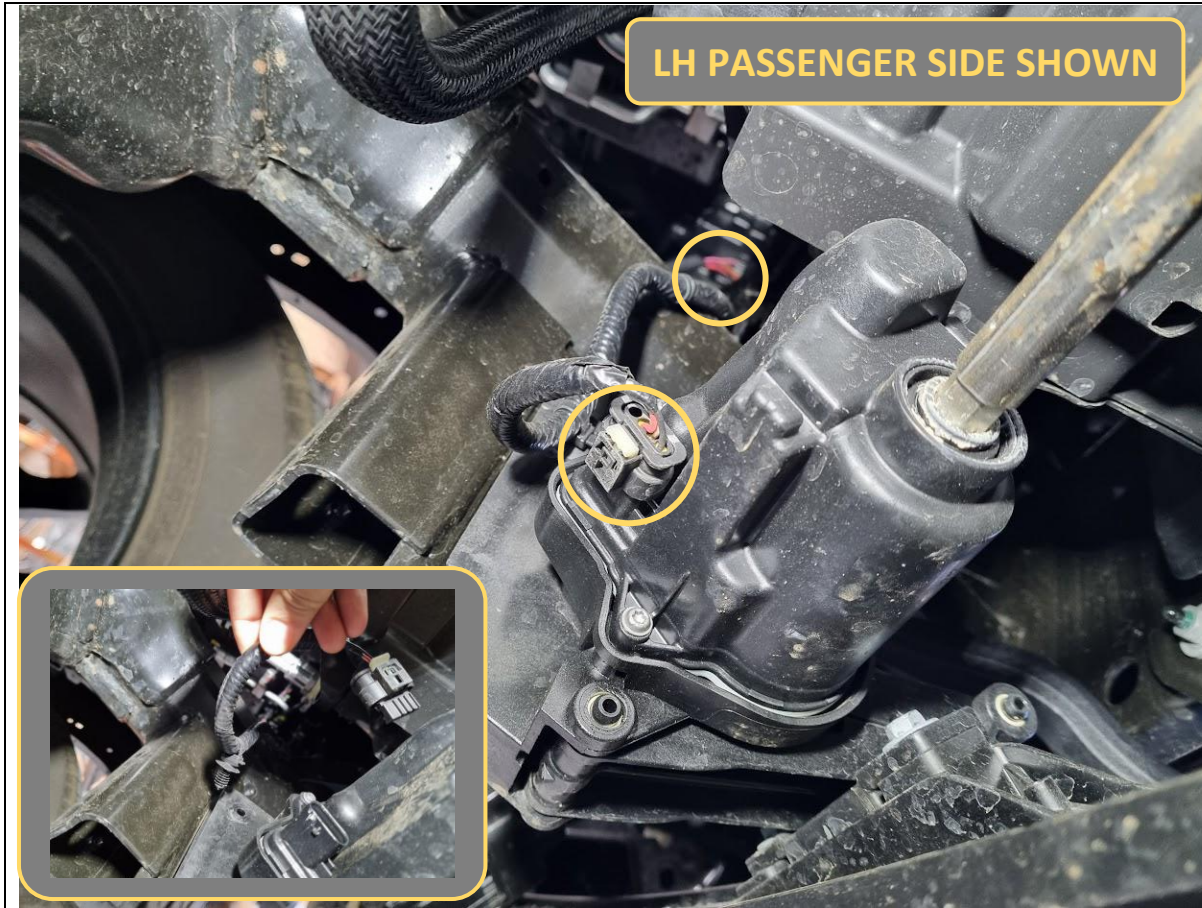

20. Locate the active air dam motor on the underside of the LH chassis rail.
21. Disconnect the plug on the air dam motor.
22. Also unclip the air dam motor harness from the air dam assembly, using a trim tool or flat blade screwdriver to assist.

TOOLS REQUIRED

Trim tool
or
Flat blade screwdriver

FASTENERS

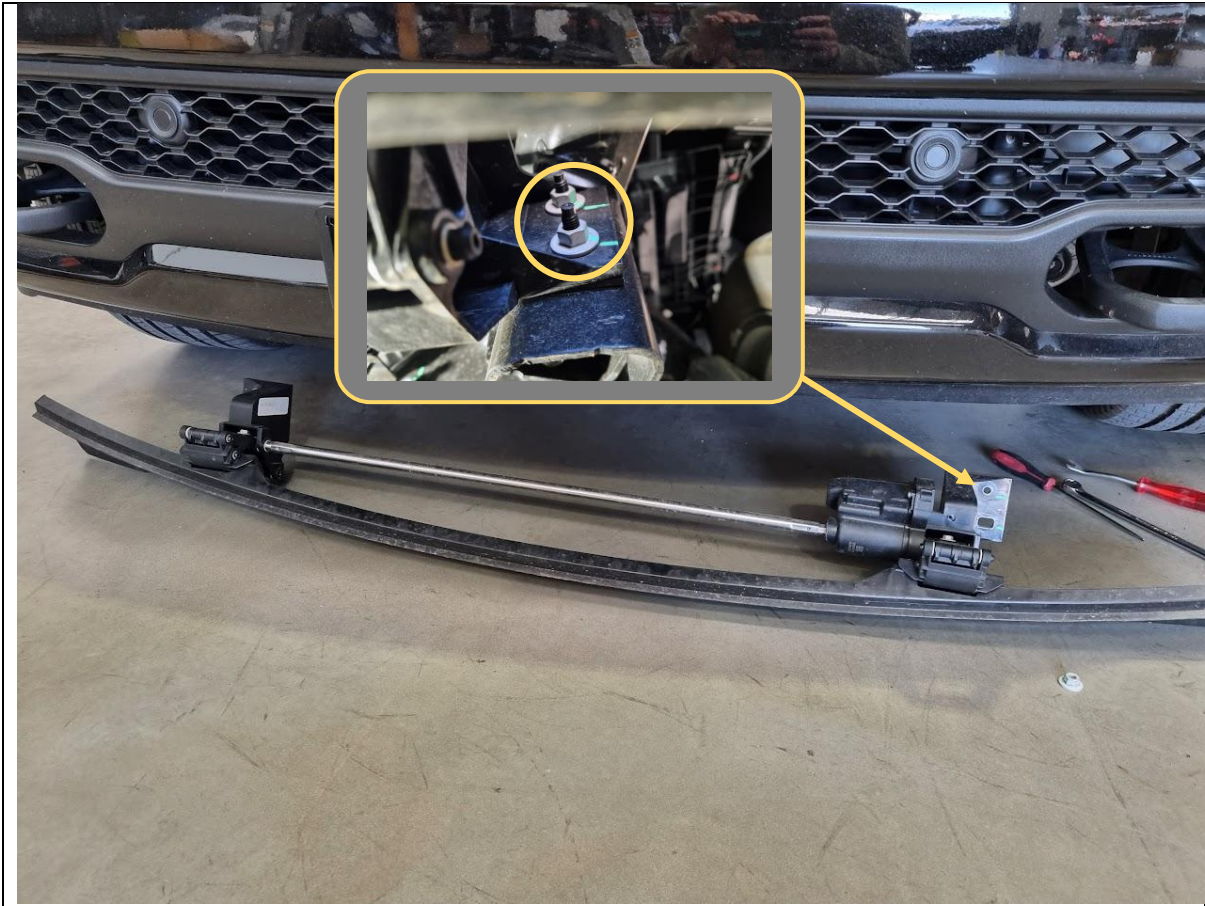

23. Remove 4x 13mm hex nuts (2x per side) holding the active air dam assembly to the chassis.

Retain the nuts for later.

Note:

Removing the active air dam assembly will not cause an engine management light (EML) on the dash, but may potentially leave a code on the ECU.

Removal of this assembly has been done and tested without issue. **However, Offroad Animal recommends not discarding the active air dam assembly components for a period of time (eg. 1 month) after bar installation in case there is a problem.**

Alternatively, the active air dam motor can be relocated into the bull bar, the procedure for that is outlined further down in these instructions.

TOOLS REQUIRED

13mm socket/spanner

FASTENERS

4x 13mm hex nuts

Retain for re-fitment

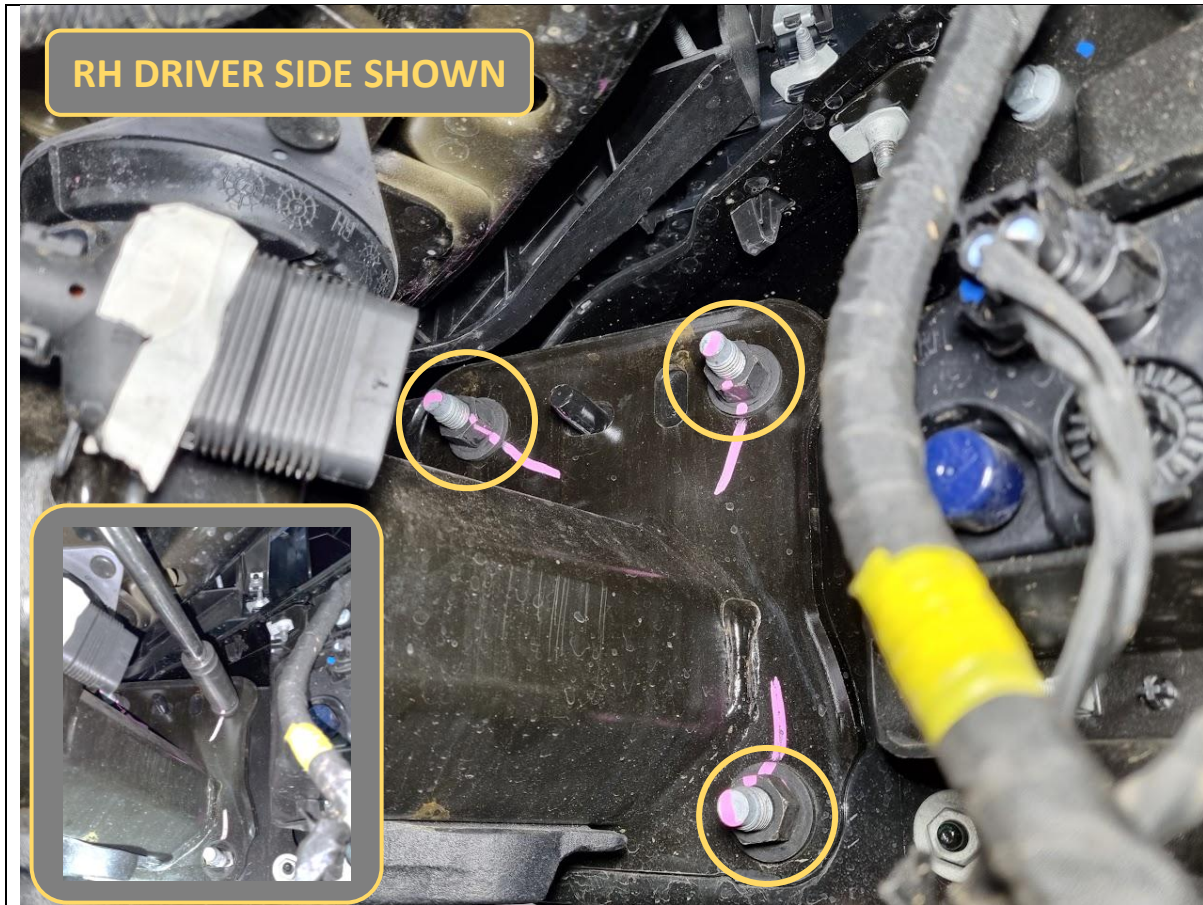

RH DRIVER SIDE SHOWN

24. Looking in from behind the bumper, remove 3x 18mm hex nuts holding the bumper to each chassis rail.

Use a socket extension bar or spanner to get access.

TOOLS REQUIRED

18mm socket/spanner
Socket extension bar

FASTENERS

6x 18mm hex nuts

Discard



25. Pull outwards to fully remove the bumper, set it aside. The bumper is quite heavy and bulky, either support it with a lifting device or use another person to assist.

TOOLS REQUIRED

FASTENERS



CAMERA RELOCATION ONLY

The following steps are only required if relocating the front 360 camera into the bull bar. If not relocating the camera, skip to **Step 39**.

- 26. Open the bonnet.
- 27. Remove 12x plastic push clips holding the radiator grille cover, then lift up to unclip and set aside.

TOOLS REQUIRED

Flat blade screwdriver
or
Trim tool

FASTENERS

12x plastic push clips

Retain for re-assembly



28. Remove 2x plastic push clips holding the top grille trim, above the headlights. 1x per side.

TOOLS REQUIRED

Flat blade screwdriver
or
Trim tool

FASTENERS

2x plastic push clips
Retain for re-assembly



CAMERA RELOCATION ONLY

- 29. Remove 8x 8mm hex bolts holding the top grille trim.
- 30. Once bolts are removed, pull outwards to remove the top grille trim.

TOOLS REQUIRED

8mm socket/spanner

FASTENERS

8x factory 8mm hex bolt

Retain for re-assembly

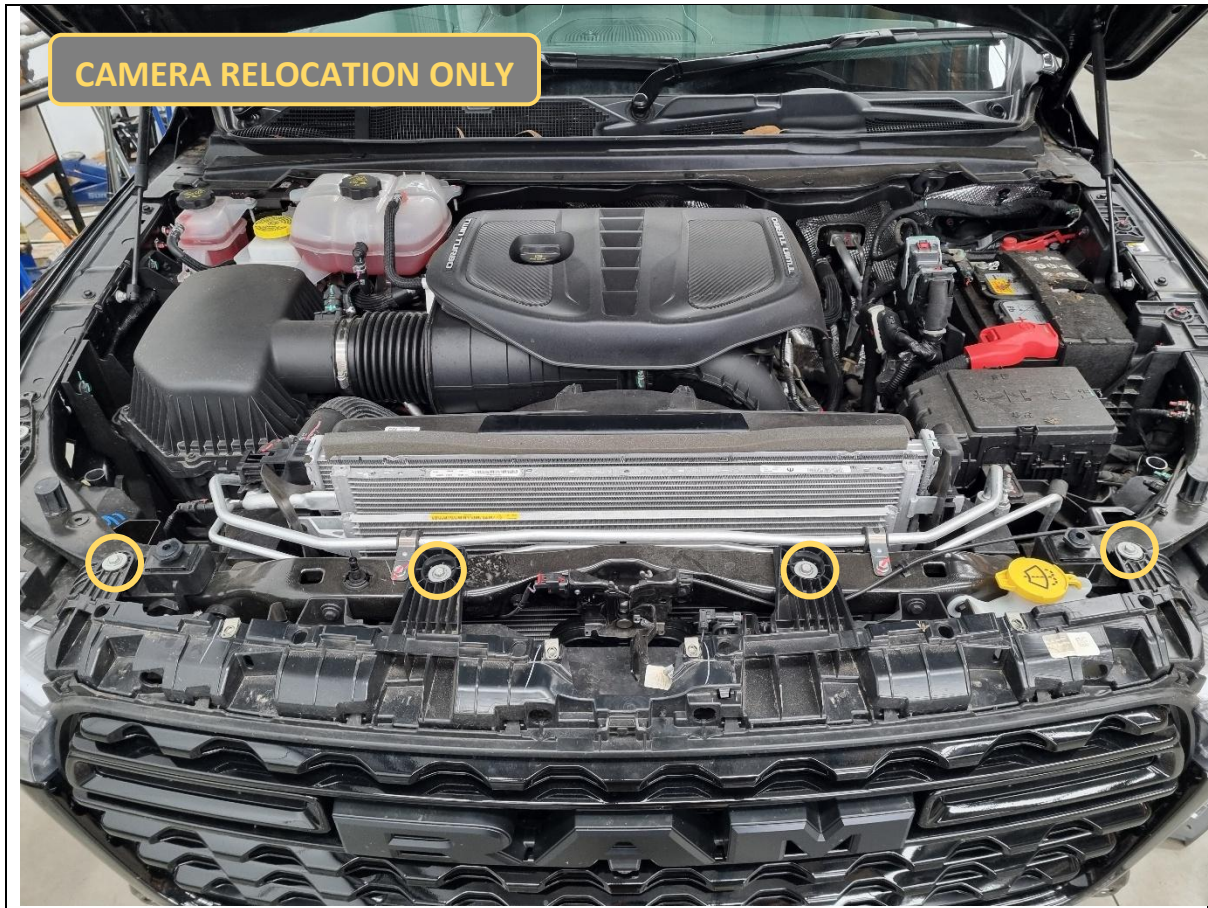

31. Remove 4x 10mm hex bolts holding the top of the main grille section.

TOOLS REQUIRED

10mm socket/spanner

FASTENERS

4x factory 10mm hex bolt

Retain for re-assembly



32. Remove 3x 10mm hex bolts holding the bottom outside corner of the main grille, per side.

TOOLS REQUIRED

10mm socket/spanner
Socket extension bar

FASTENERS

6x factory 10mm hex bolt
Retain for re-assembly

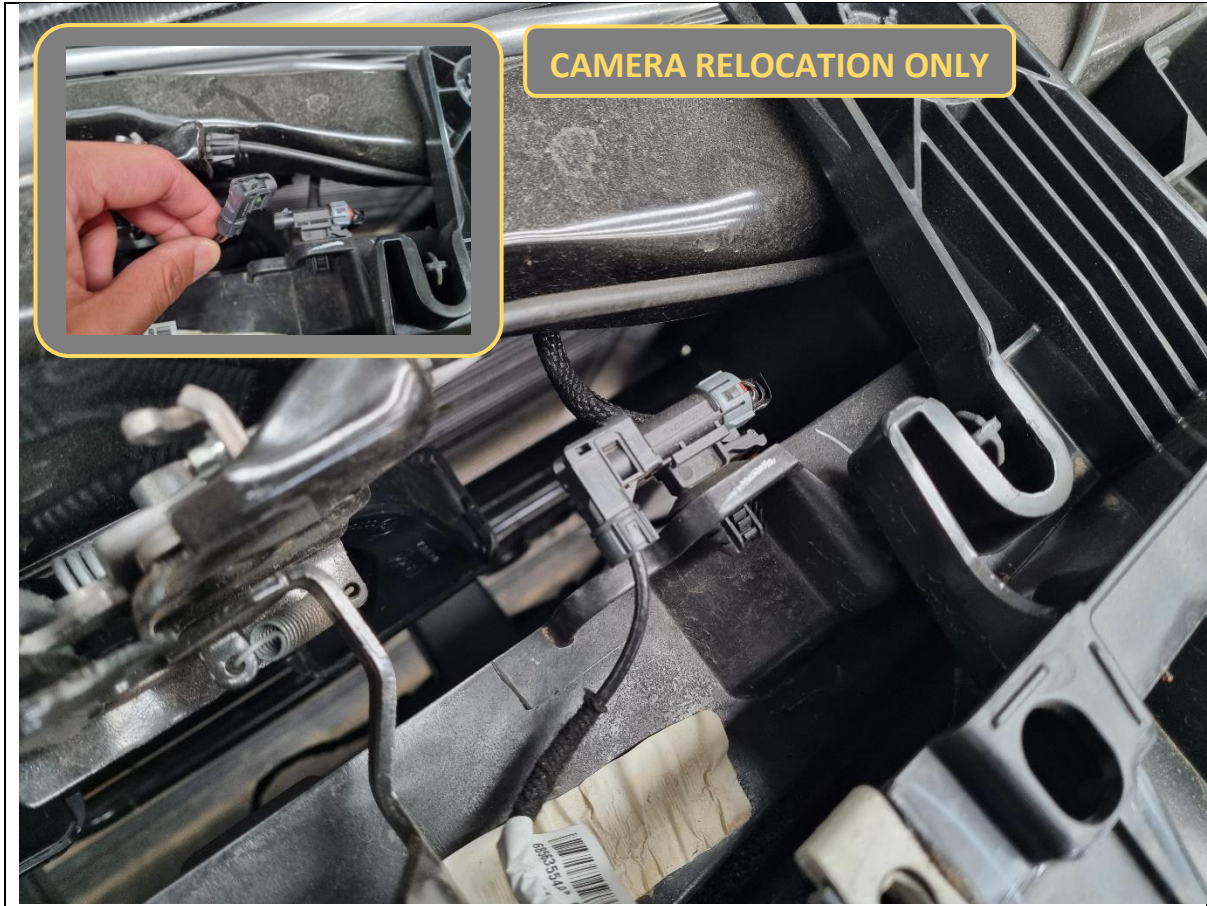

33. Locate the camera plug at the top of the grille, near the bonnet release handle, and unplug.

TOOLS REQUIRED

FASTENERS



34. Lift the grille up over the retaining pins and fully remove from the vehicle.

TOOLS REQUIRED

FASTENERS

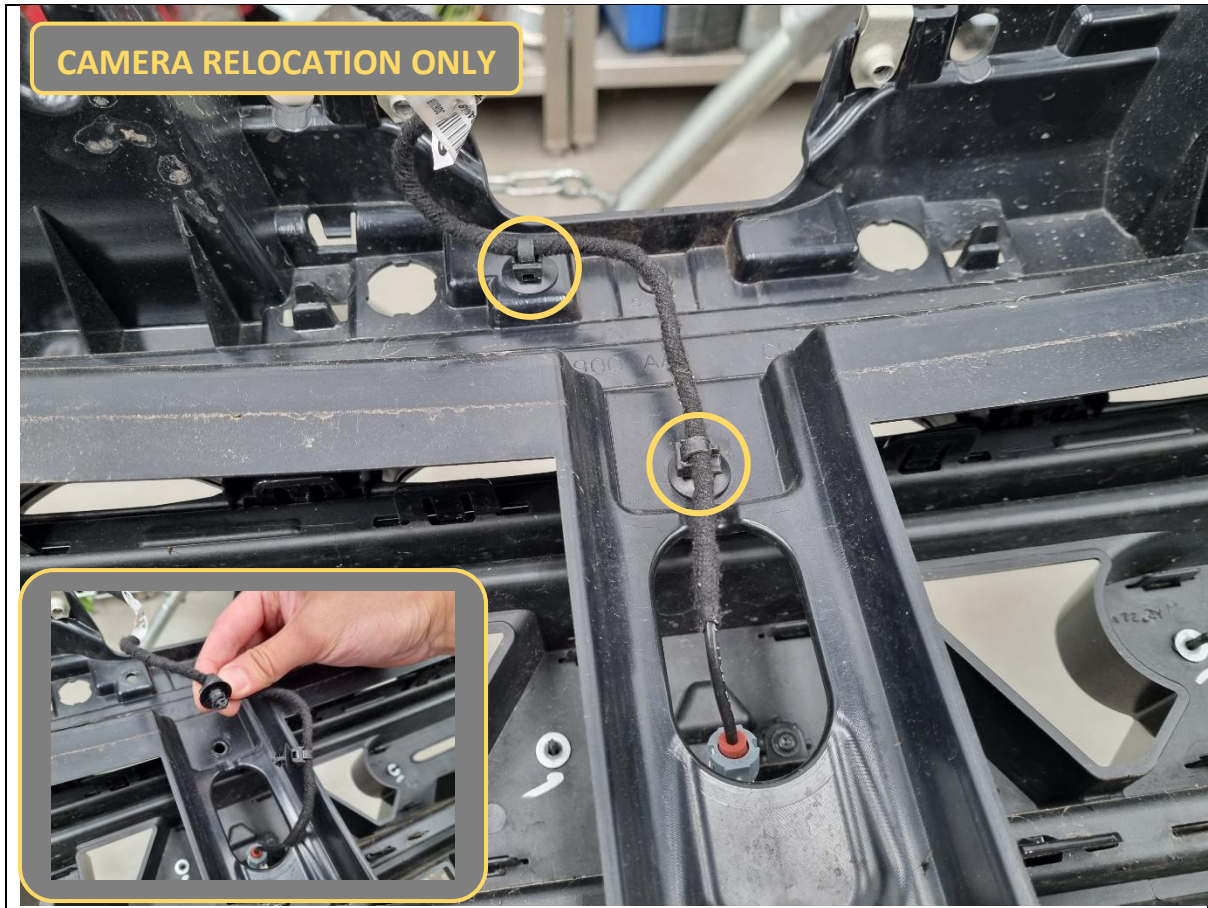

35. Unclip 2x clips holding the camera harness to the back of the grille.

TOOLS REQUIRED

Trim removal tool

FASTENERS



- 36. Remove 2x T10 Torx screws holding the camera and mounting bracket to the grille.
- 37. Remove the camera assembly and set aside in a safe place for relocation later.

TOOLS REQUIRED

T10 Torx bit

FASTENERS

2x T10 Torx screw

Discard



38. Re-fit the grille, top trim and radiator cover in reverse order.

TOOLS REQUIRED

- 8mm socket/spanner
- 10mm socket/spanner
- Socket extension bar

FASTENERS

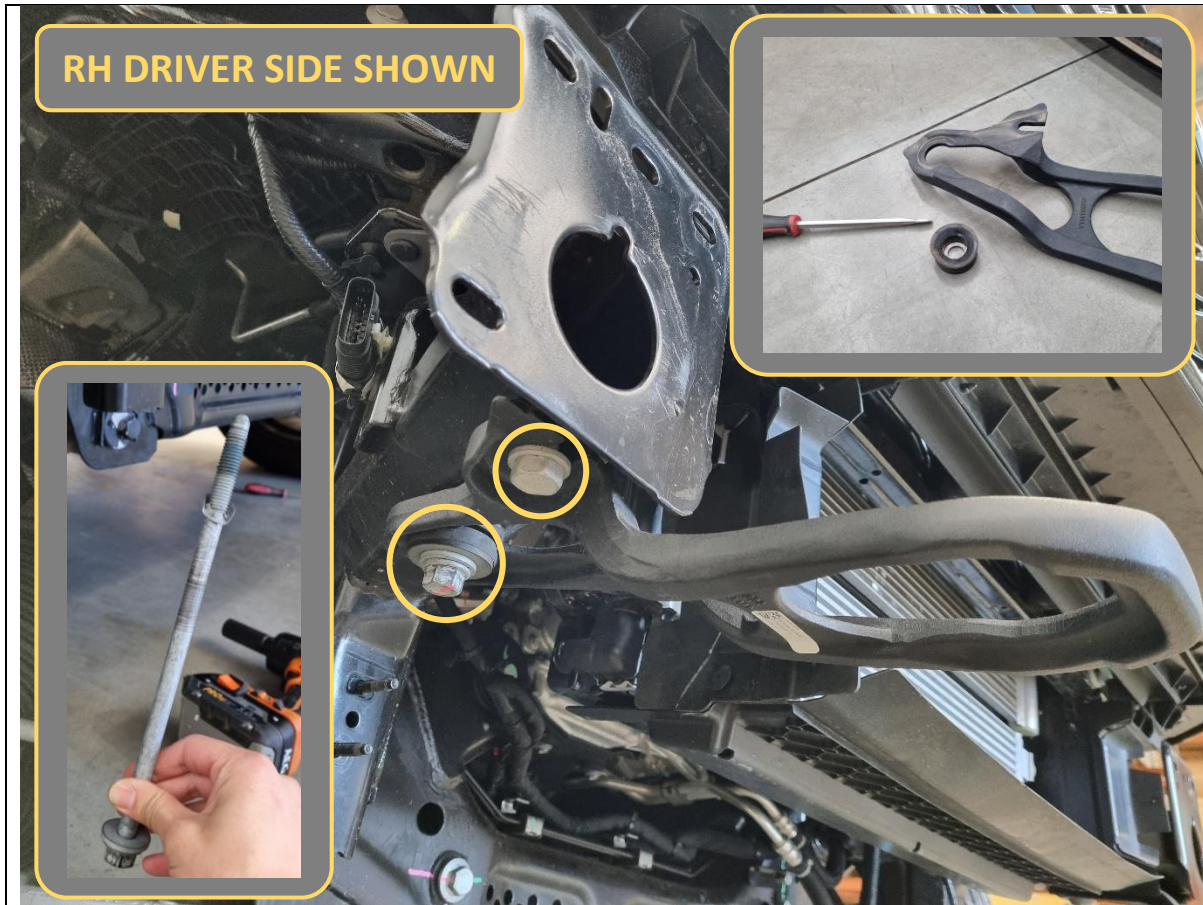

39. Remove 1x 18mm hex bolt (rear) and 1x 21mm hex bolt (front) holding each tow hook to the underside of the chassis. Retain both bolts.

Note: The 18mm hex bolt has a keeper/retention washer into the body mount that may be lodged in sideways (see bottom left inset). In some cases, you may need to hammer the bolt out. It is ok to discard the keeper washer.

40. Remove the rubber bush from each tow hook and set aside for re-use. The tow hooks may be discarded.

TOOLS REQUIRED

18mm socket/spanner
21mm socket/spanner

FASTENERS

2x factory 18mm hex bolt
2x factory 21mm hex bolt
2x factory rubber bush

Retain for re-assembly

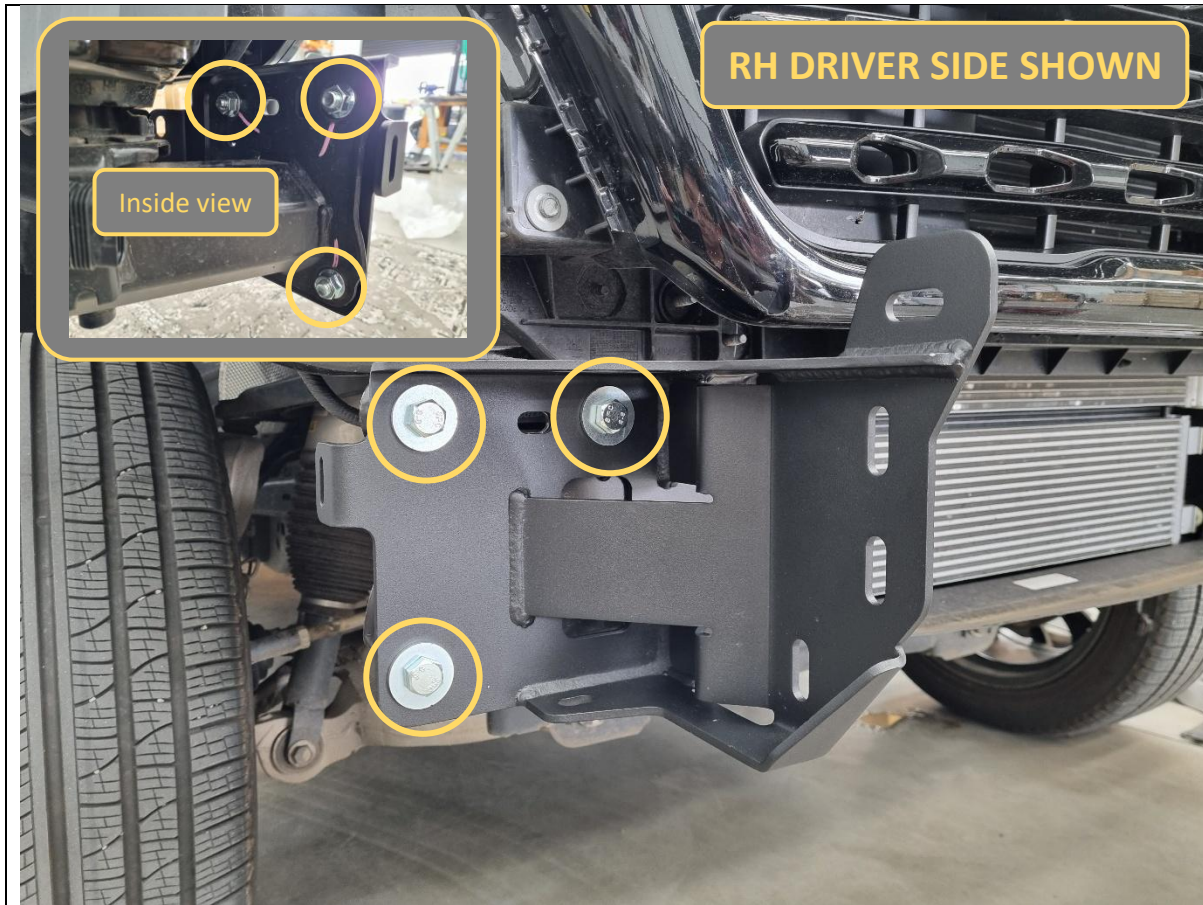

41. Fit the impact assemblies to the ends of the chassis.

42. Finger tight secure each impact assembly with 3x M12x30 hex bolts, washers and flange nuts.

Leave the middle hole/slot empty for now. You can use it for reference when aligning and centering the mounts.

TOOLS REQUIRED

FASTENERS

- 6x M12x30 hex bolt
- 6x M12 flat washer
- 6x M12 flange nut

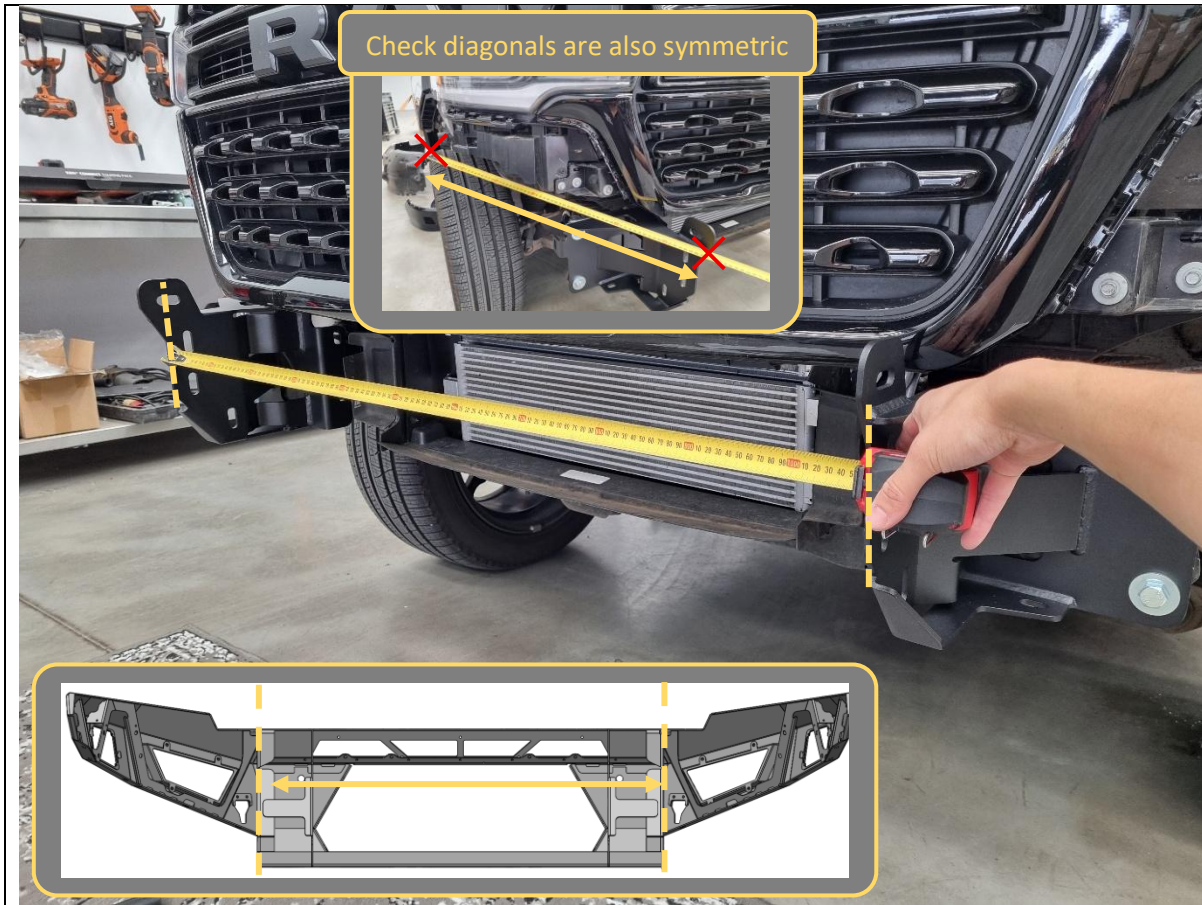

43. Measure the distance between the outside faces of the uprights on the bull bar using a tape measure. Write the distance below for reference if required:

Bar upright width = _____ mm

44. Adjust the impact assemblies by sliding left/right on the slots, such that the distance between the inner mounting faces of the impact assemblies is 2-4mm more than the bull bar distance. Ensure the mount faces are vertically upright and symmetric left/right on the vehicle (measure to the corners of the headlights or similar to check).

45. Once happy with alignment, tighten all 6x M12 bolts to recommended torque.

TOOLS REQUIRED

- Tape measure
- 18/19mm socket/spanner
- Socket extension bar

FASTENERS

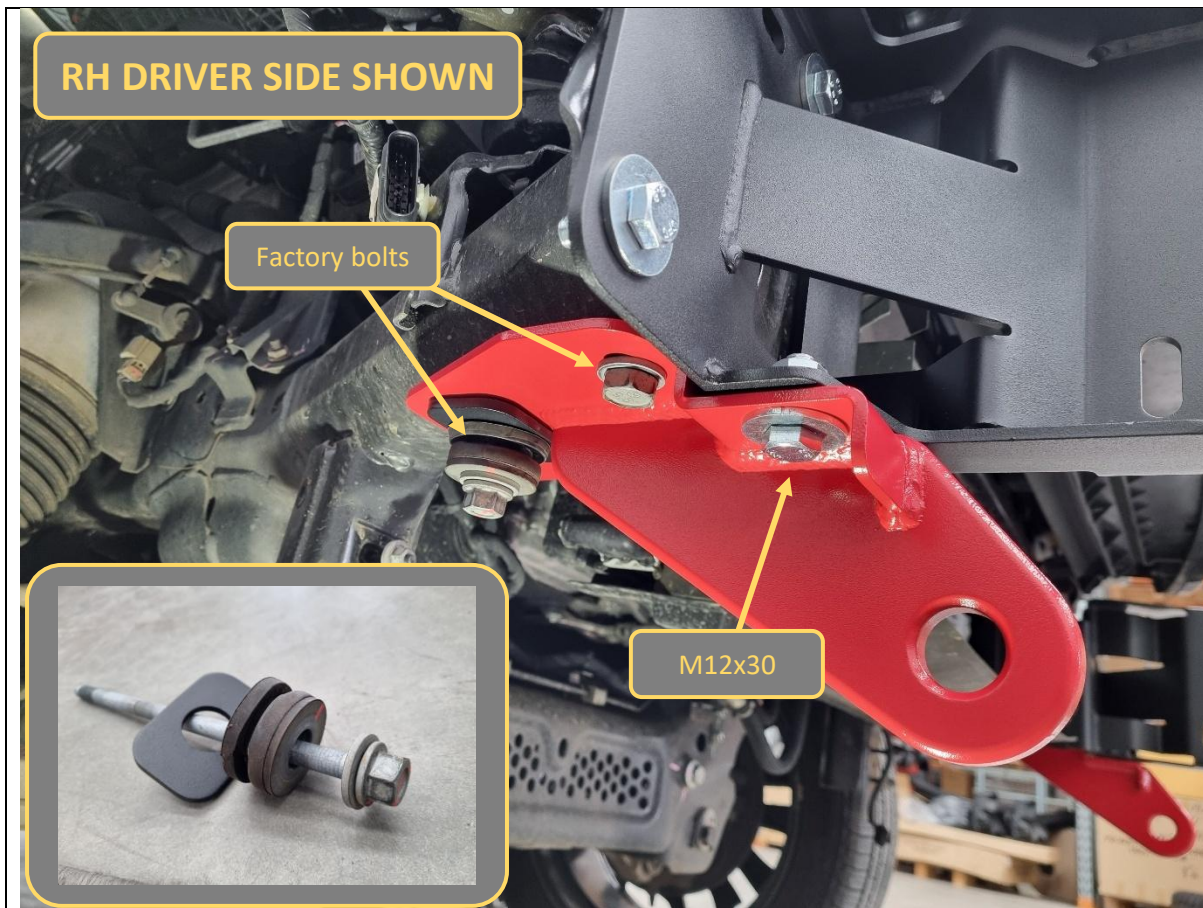

- 46. Fit the factory rubber bush and P-0507 spreader plate onto the long factory 18mm hex bolt, as shown in inset photo.
- 47. Fit the tow point from underneath the chassis, and loosely secure re-using the factory 18mm and 21mm hex bolts.
- 48. Loosely secure the front end to the bottom of the impact assembly with 1x M12x30 hex bolt, washer and flange nut.
- 49. Do this for both sides.

TOOLS REQUIRED

FASTENERS

- 2x factory 18mm hex bolt
- 2x factory 21mm hex bolt
- 2x factory rubber bush

- 2x M12x30 hex bolt
- 2x M12 flat washer
- 2x M12 flange nut



50. Loosely secure the inner face of the tow point to the impact assembly with 2x M12x30 hex bolts, washers and flange nuts.
- Flange nuts on the inside can be accessed through the cutout on the side of the tow point, and from reaching over the chassis rail from the outside.
51. Snug up all tow point bolts so that all faces of the tow point are sitting flush against the chassis and impact assembly, then fully tighten to recommended torque.
- 5x bolts in total, per tow point.
52. Do this for both sides.

TOOLS REQUIRED

- 18mm socket/spanner
- 19mm socket/spanner
- 21mm socket/spanner

FASTENERS

- 4x M12x30 hex bolt
- 4x M12 flat washer
- 4x M12 flange nut



RH DRIVER SIDE SHOWN

53. Fit the remaining M12x30 hex bolt, washer and flange nut to each impact assembly front face and tighten to recommended torque.

TOOLS REQUIRED

18/19mm socket/spanner
Socket extension bar

FASTENERS

2x M12x30 hex bolt
2x M12 flat washer
2x M12 flange nut

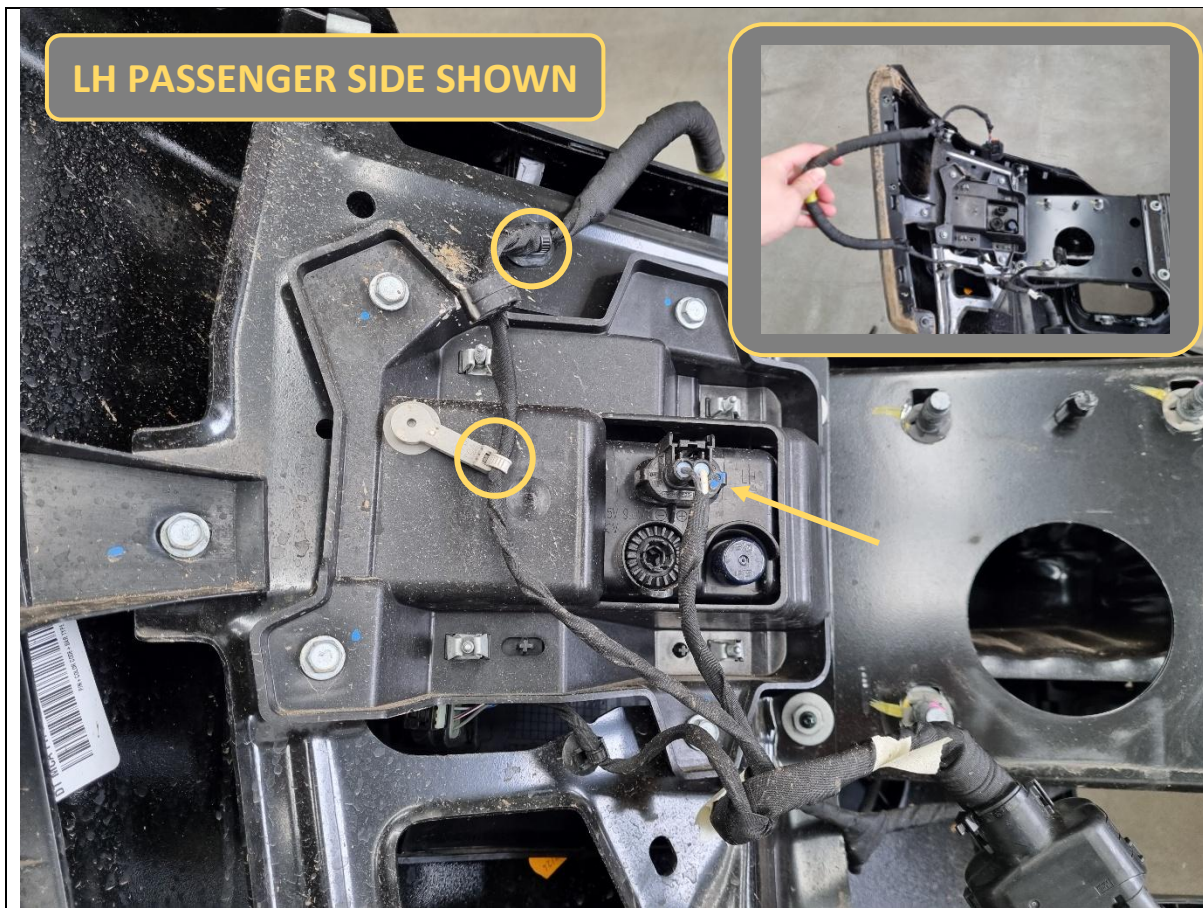

Time to strip the bumper. The following steps will suit Laramie Sport, Express Black Edition and Limited. The Rebel has a different bumper so some things may be slightly different.

- 54. Unplug the fog lights and unclip any harnesses clipped to the fog light (can also cut the clip, just be careful to not snip any electrical wires in the harness).

TOOLS REQUIRED

Trim removal tool
or
Side cutters

FASTENERS

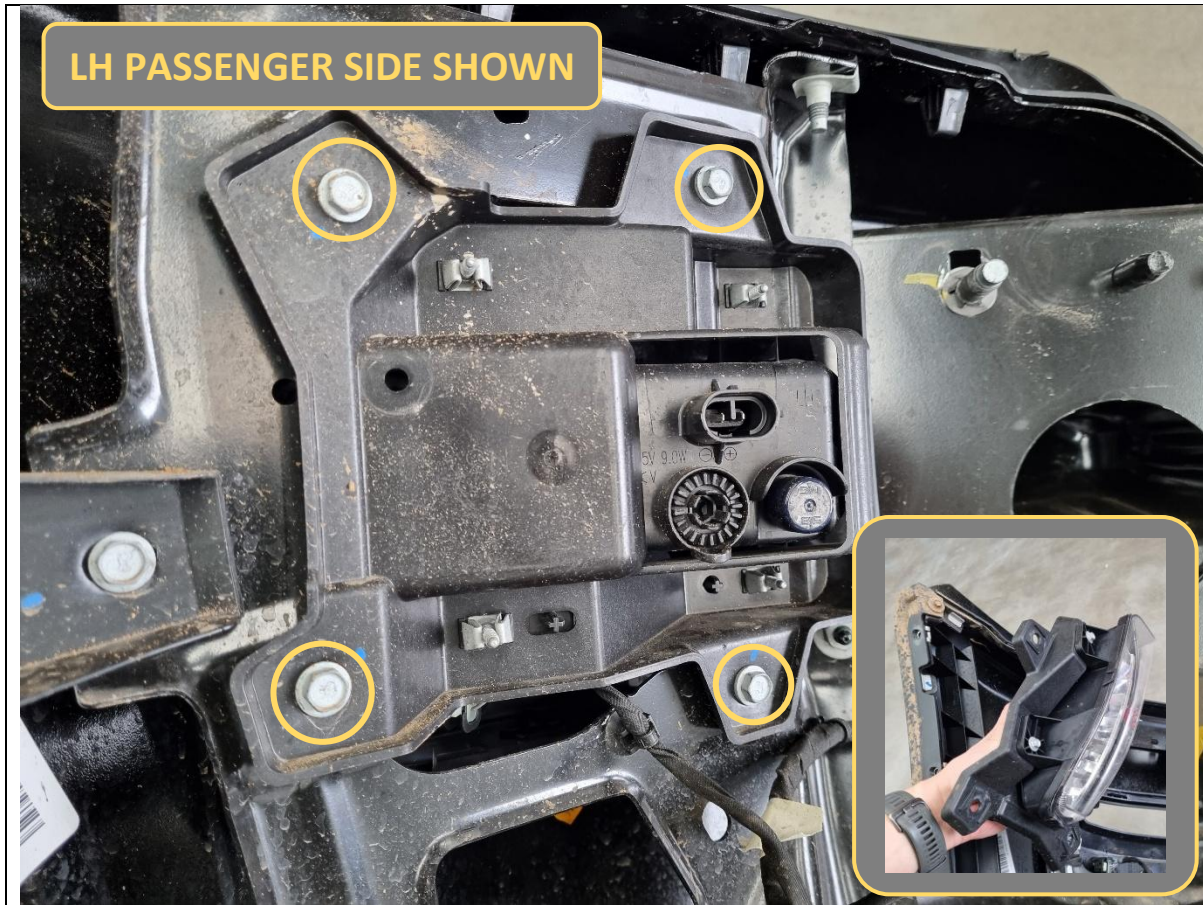

- 55. Remove 4x 10mm hex bolts holding each fog light.
- 56. Remove the fog lights from the bumper. These are too big to be re-used in the bull bar, so can be discarded.

TOOLS REQUIRED

10mm socket/spanner

FASTENERS

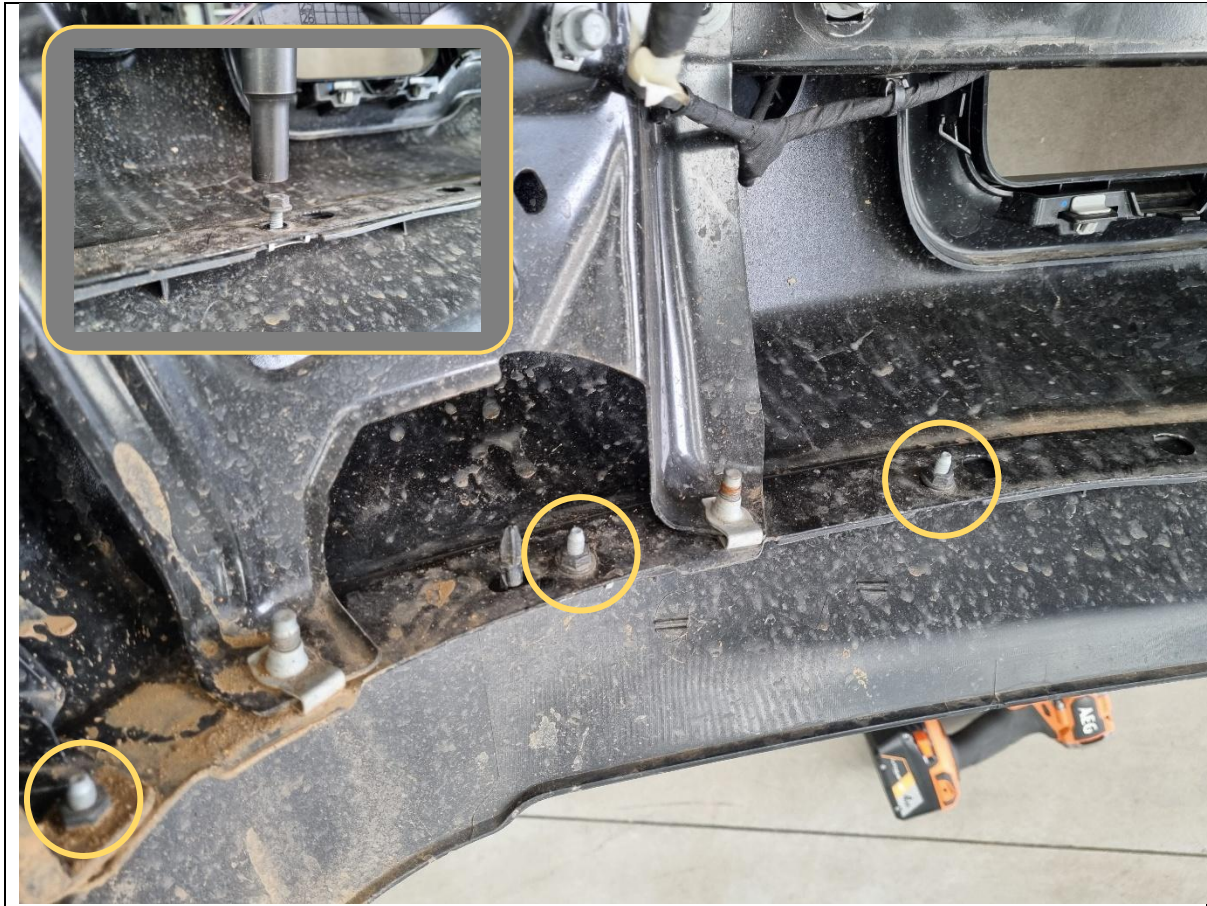

57. Remove 14x 10mm hex nuts holding the lower plastic spoiler to the bumper.

TOOLS REQUIRED

10mm socket/spanner

FASTENERS

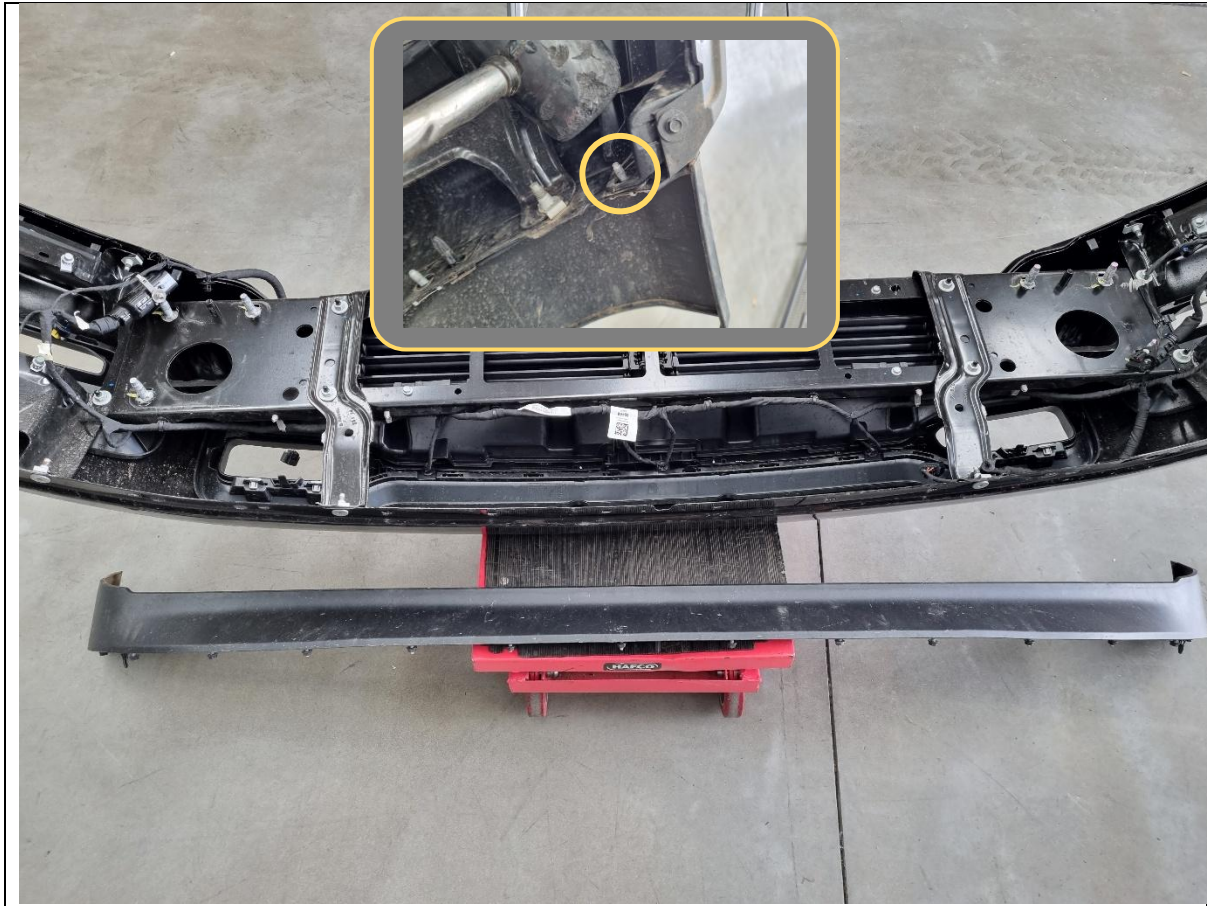

58. Pull and remove the lower spoiler to reveal hidden Torx bolts underneath.

If the threaded studs on the spoiler are jamming in the holes in the bumper, you may need to use a hammer to push them out (see inset photo).

TOOLS REQUIRED

FASTENERS



59. Remove 2x plastic push clips holding each of the upper spoilers to the bumper and pull/unclip out to reveal hidden Torx bolts underneath.

TOOLS REQUIRED

FASTENERS



- 60. Locate the outermost parking sensor on each side (2x total) and unclip them from the bumper by spreading open the locking tabs.

‘Rebel’ bumper is different, 4x of the 6x parking sensors can be accessed and unclipped now.
- 61. Take note of the sensor plug orientation as this will need to be matched in the bull bar.
- 62. ‘Laramie Sport’ and ‘Express Black Edition’ also has a marker lamp next to the parking sensor. Unfortunately, the lamp can’t be re-used due to the special housing. Snip the wires for them instead. These will get connected to separate supplied replacement lamps later.

TOOLS REQUIRED

FASTENERS

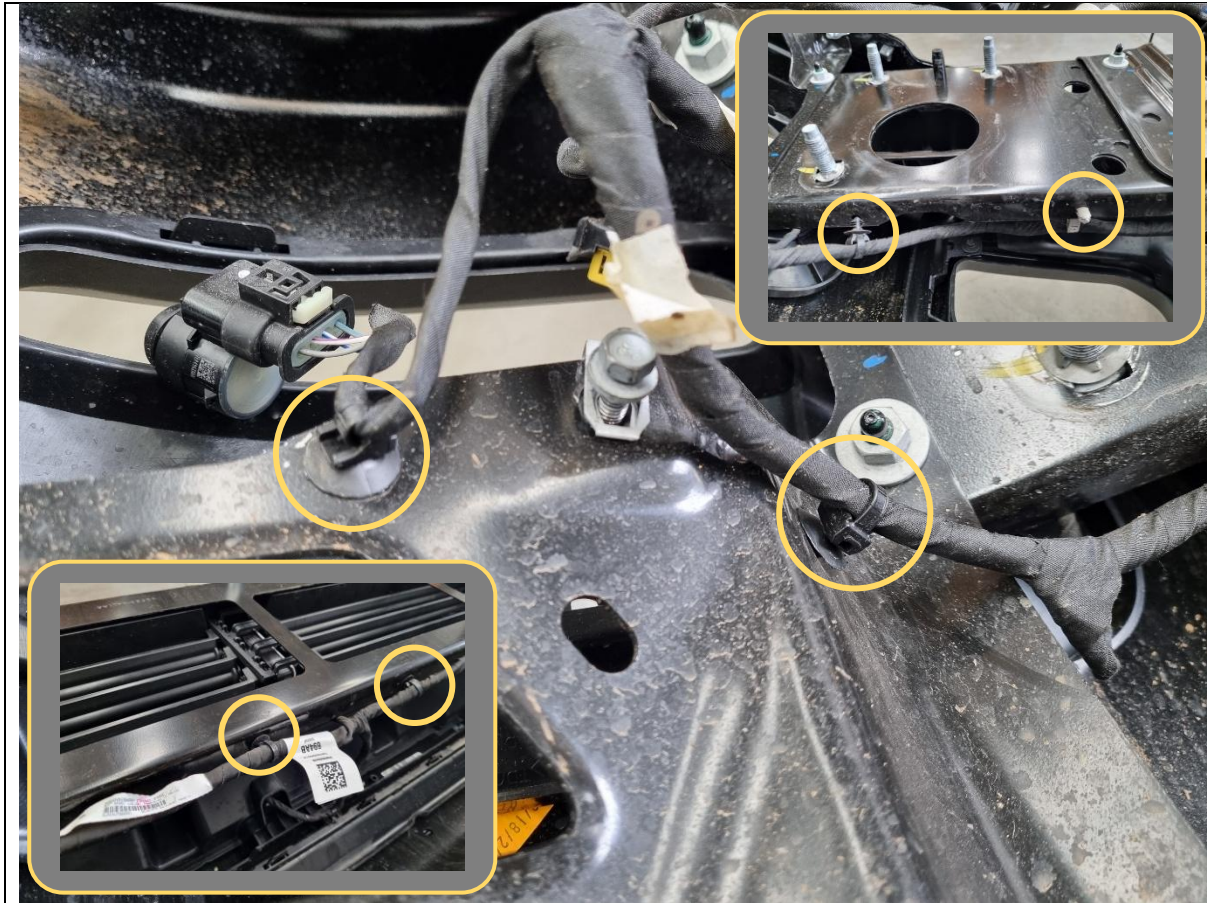

63. Unclip as much of the bumper harness as possible from the inner steel bumper structure (can also cut the clip, just be careful to not snip any electrical wires in the harness).

All the black-coloured clips should be accessible, there will be 4x white clips in the centre section that are difficult to reach. This can be left until later.

TOOLS REQUIRED

Trim removal tool
or
Side cutters

FASTENERS

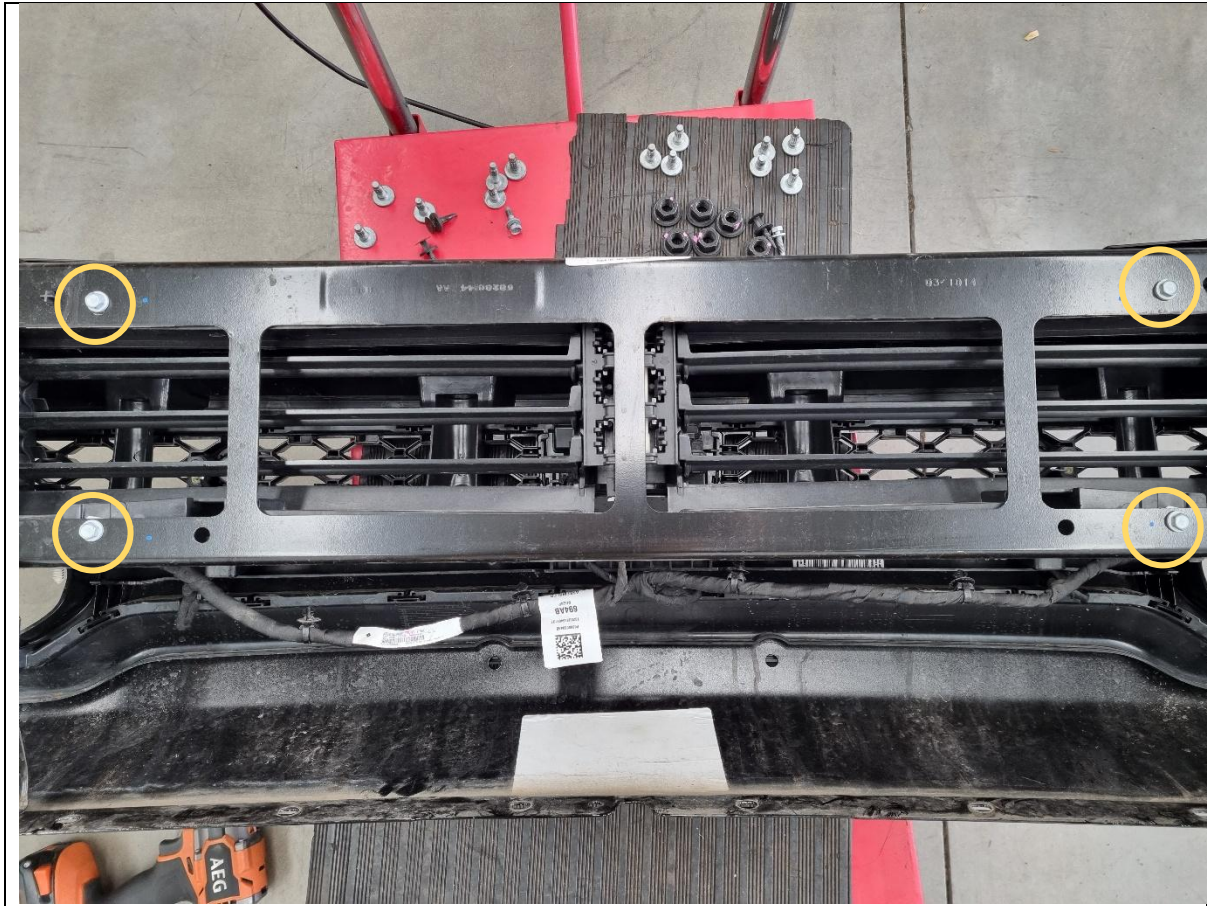

64. If present, remove 4x 10mm hex bolts holding the shutter assembly to the inner steel bumper structure.

TOOLS REQUIRED

10mm socket/spanner

FASTENERS

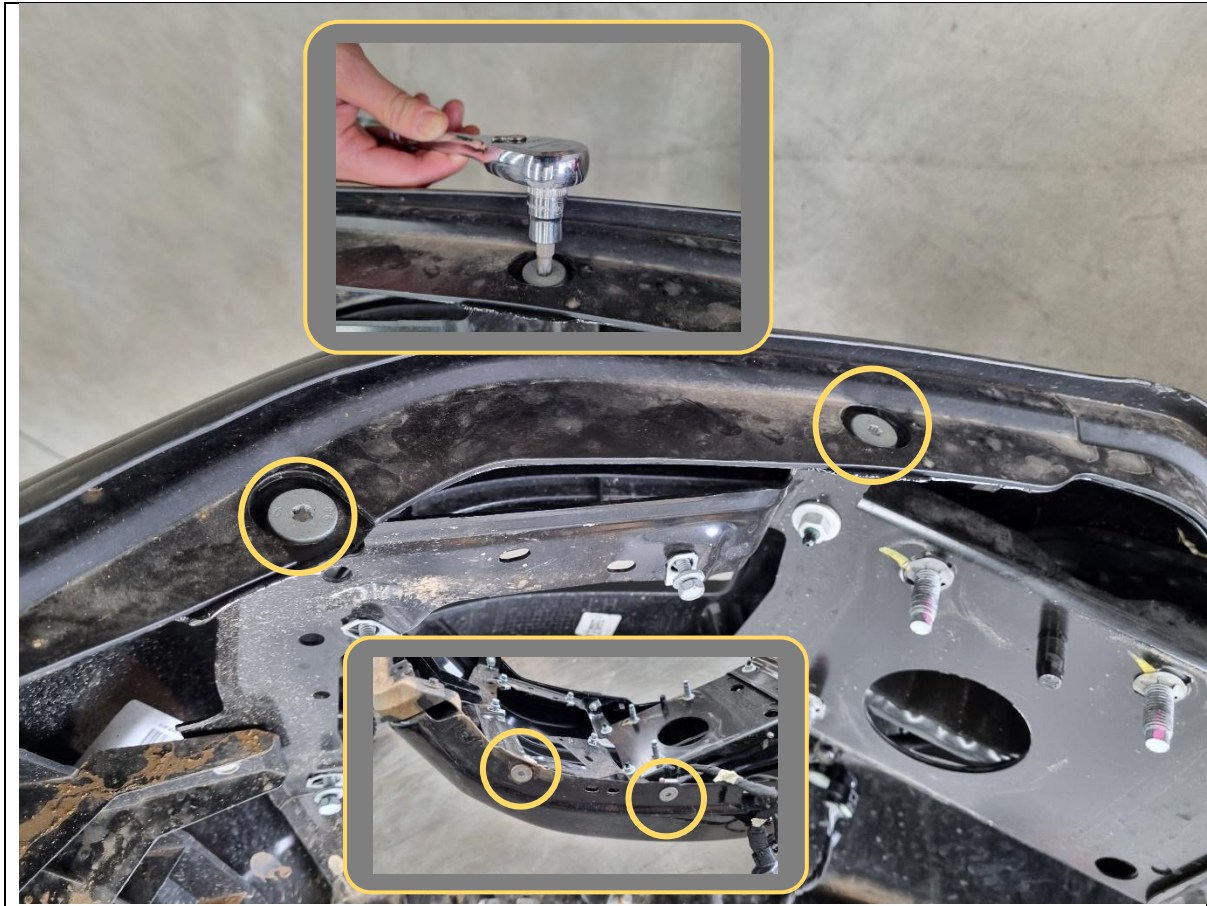

65. Remove 14x T40 Torx bolts holding the inner steel bumper structure to the top and bottom of the outer shell.

TOOLS REQUIRED

T40 Torx bit

FASTENERS

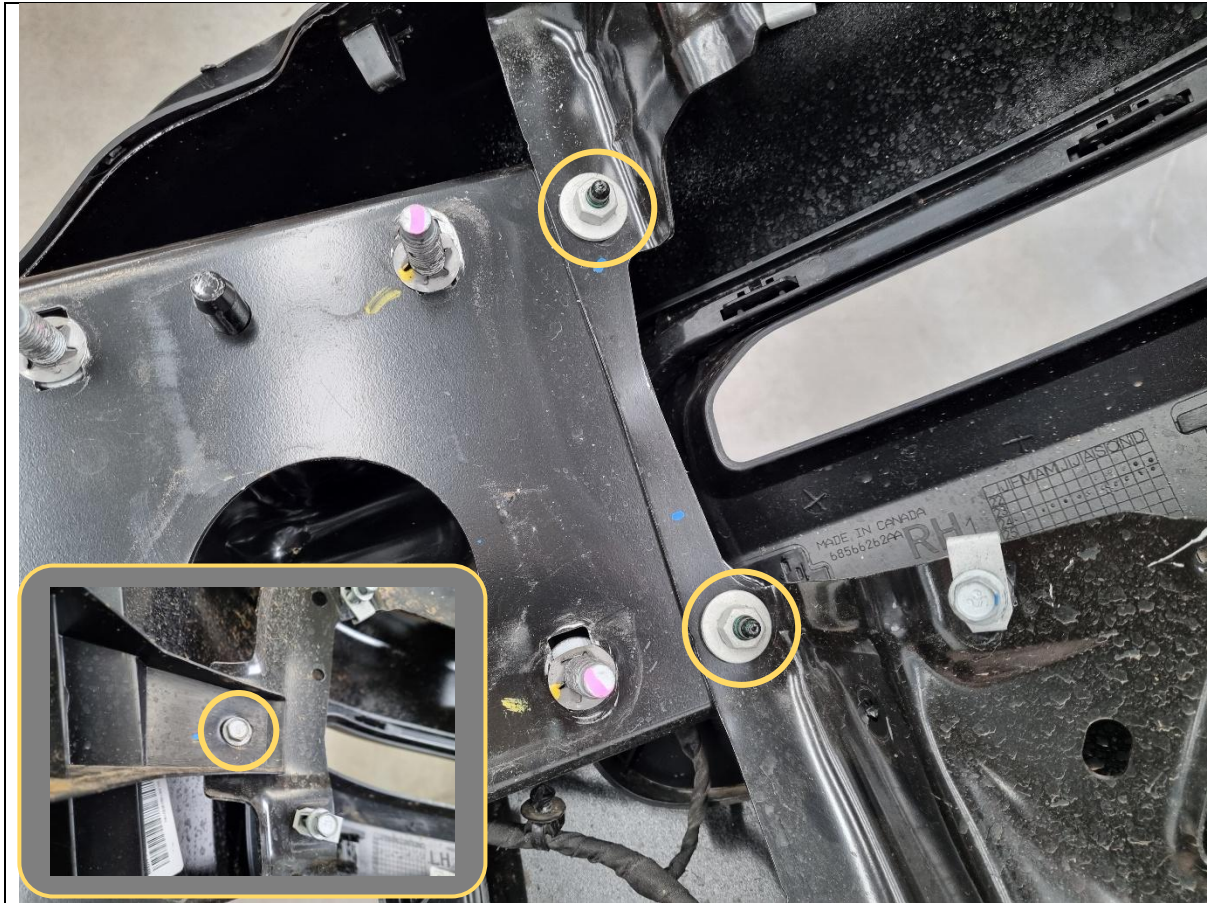

- 66. Remove 2x 13mm hex nuts holding each outer section of the inner steel bumper structure to the centre section. Repeat for other side.
- 67. Also remove 1x 10mm hex bolt holding each outer section of the inner steel bumper structure to the outer end of the main bumper (see inset photo). Repeat for other side.

TOOLS REQUIRED

10mm socket/spanner
13mm socket/spanner

FASTENERS

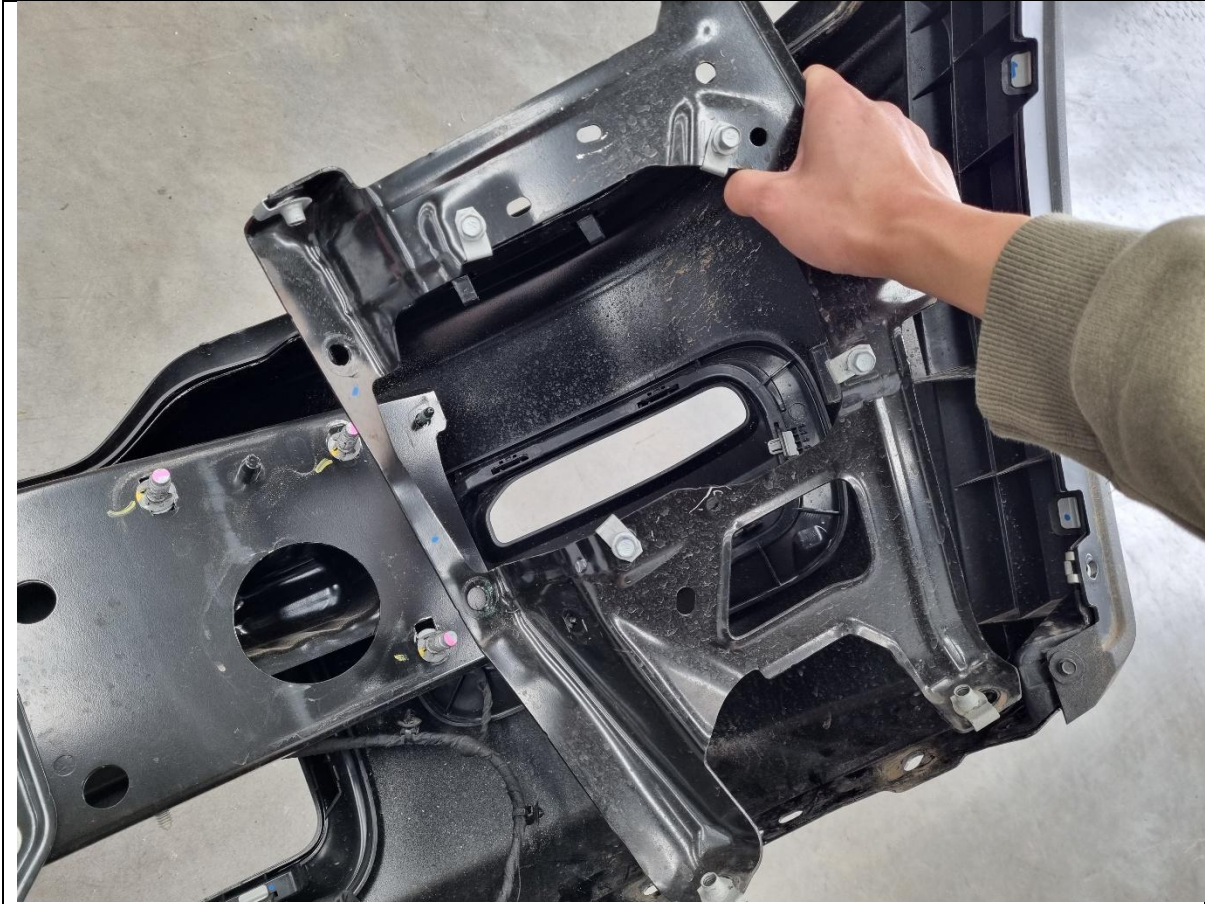

68. With all bolts removed and harness unclipped, lift out the outer sections of the inner steel bumper structure and discard.

TOOLS REQUIRED

FASTENERS

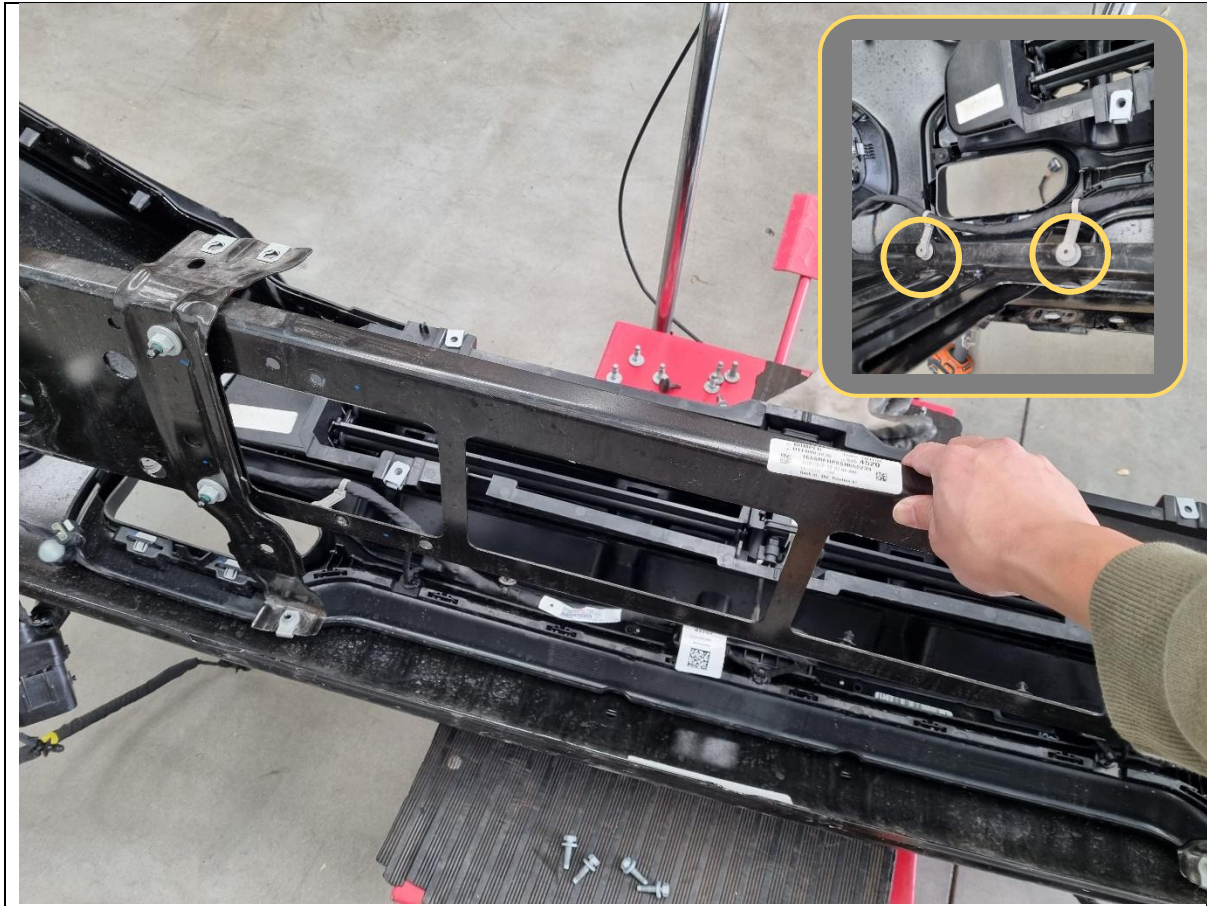

69. Lift up the centre section of the inner steel bumper structure. Unclip the remaining 4x white clips holding the bumper harness.

TOOLS REQUIRED

Trim removal tool
or
Side cutters

FASTENERS

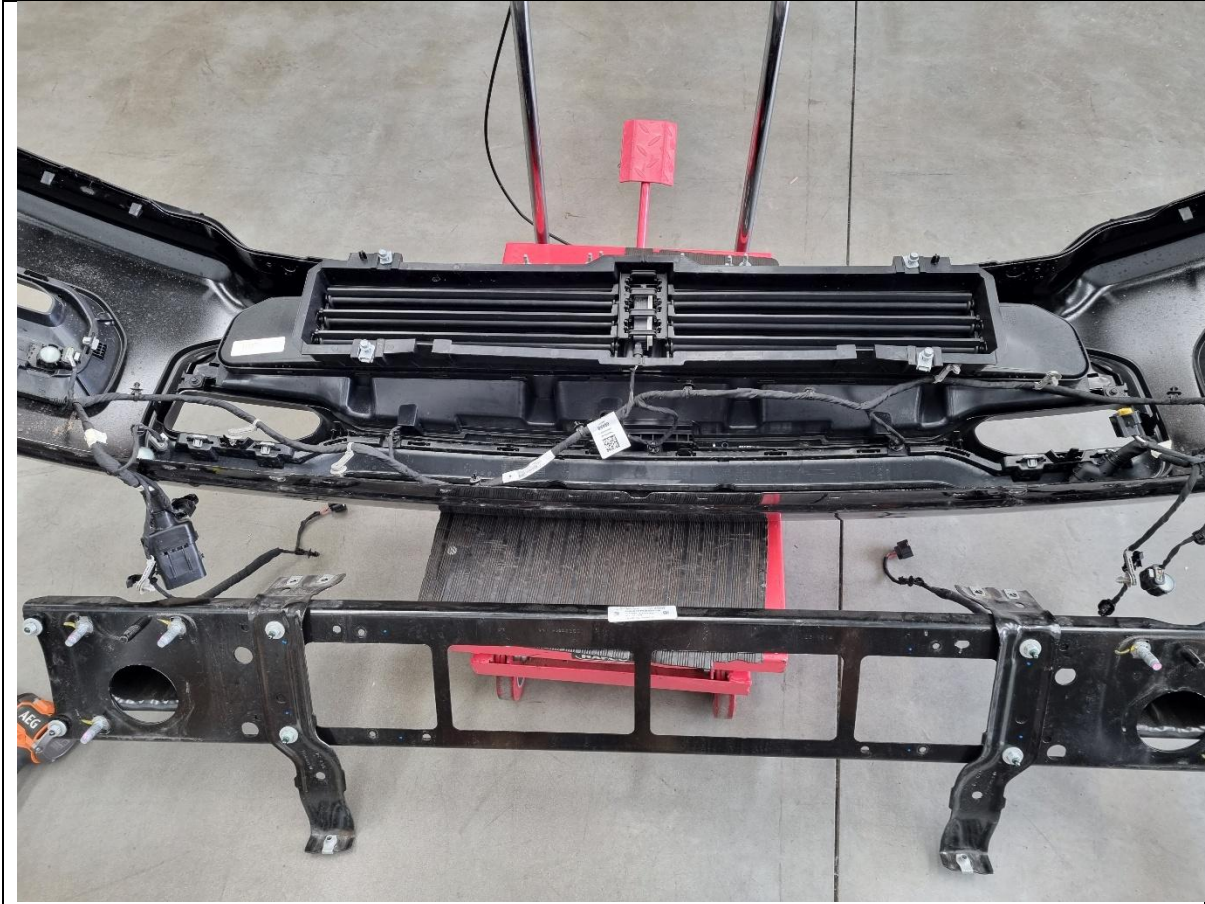

70. Bumper should now look like this with the inner steel structure removed.

TOOLS REQUIRED

FASTENERS

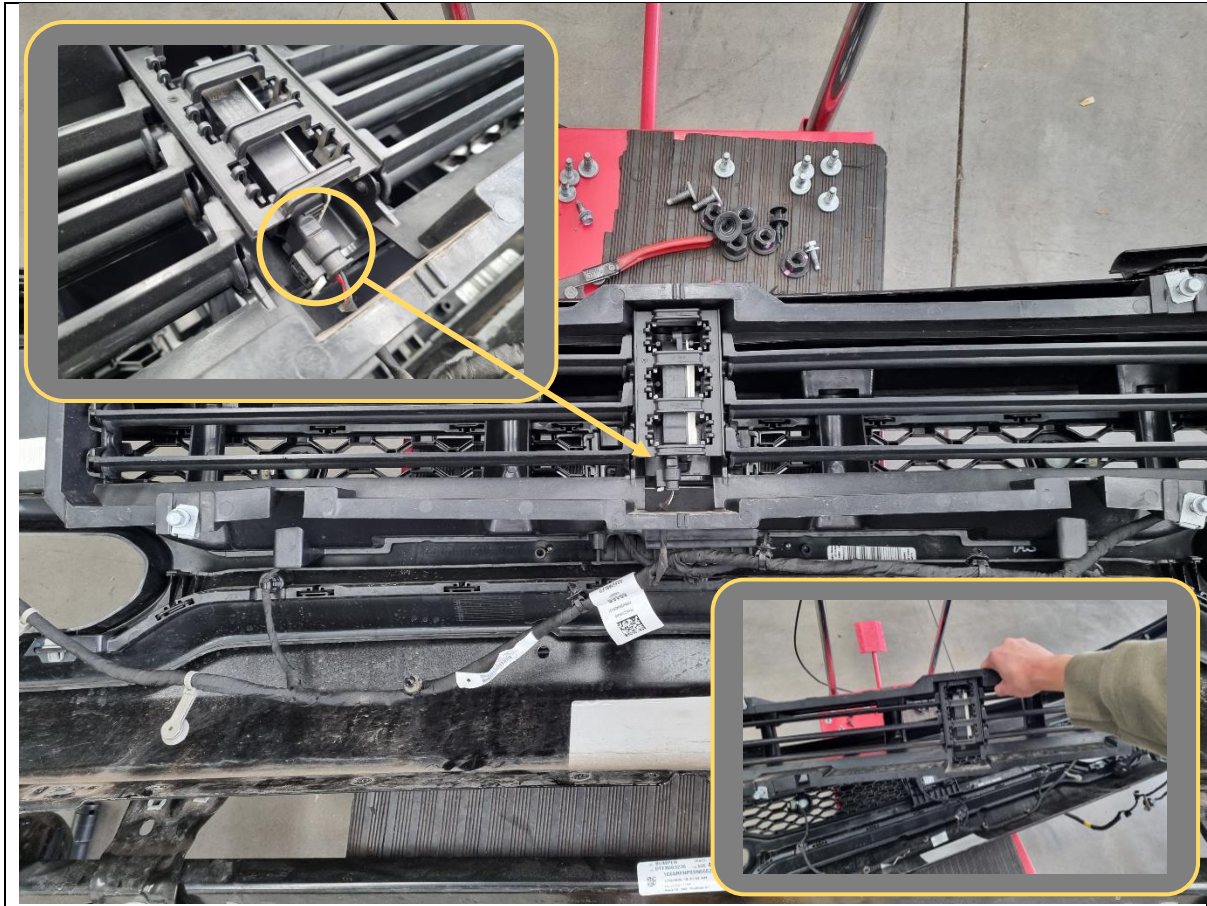

71. If present, unplug the shutter motor, then lift up and remove the entire shutter assembly. Set aside in a safe place.

TOOLS REQUIRED

FASTENERS

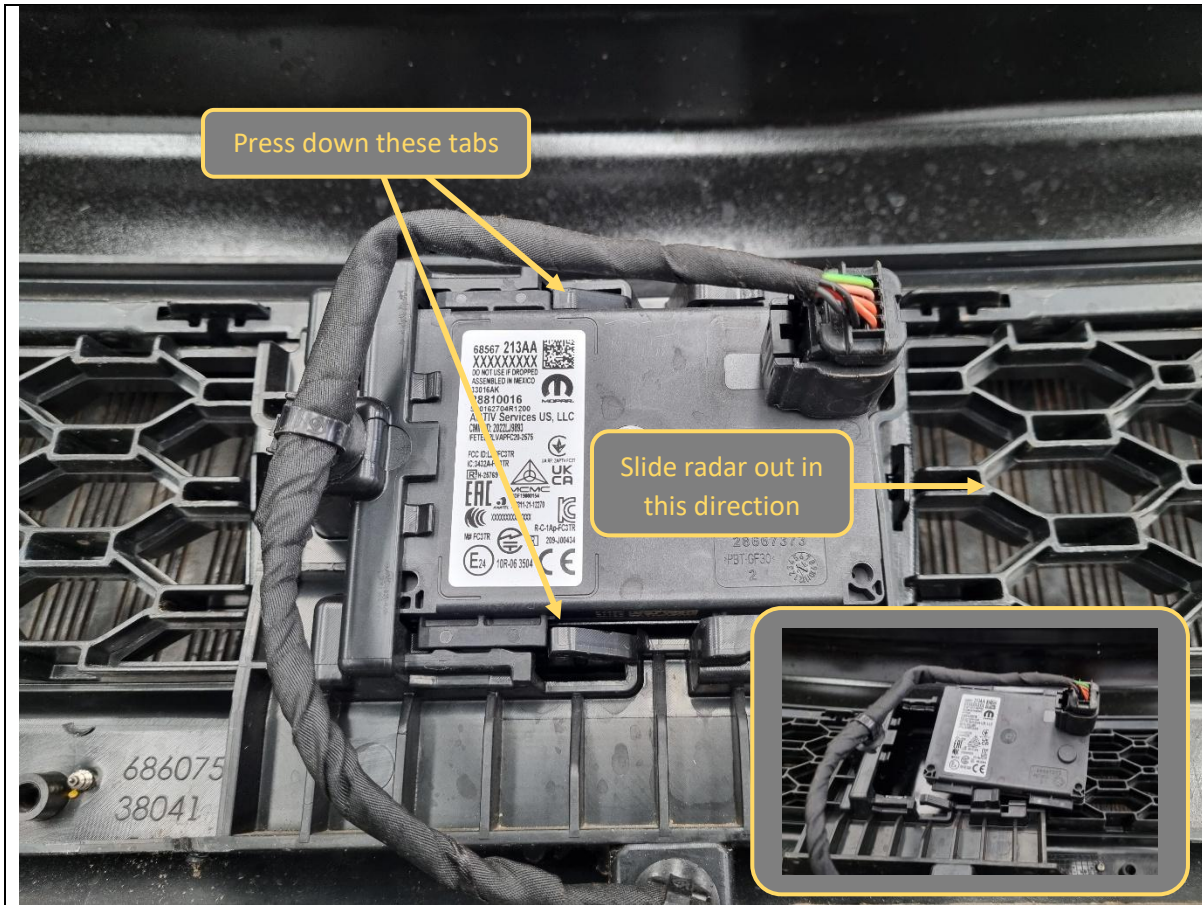

- 72. Locate the centre radar behind where the shutter assembly was.
- 73. Press down on the locking tabs and slide the radar out. Take note of the radar orientation.

Warning: Do not drop or impact the radar.

TOOLS REQUIRED

FASTENERS



- 74. Unclip remaining parking sensors, then unclip the bumper harness and remove from the bumper.
- 75. Label the parking sensors with their respective location in the bumper (LH outer, RH inner, etc.), then disconnect from the harness and place them somewhere safe.
- 76. Also unplug the radar from the harness and place it somewhere safe.

TOOLS REQUIRED

Trim removal tool
or
Side cutters

FASTENERS

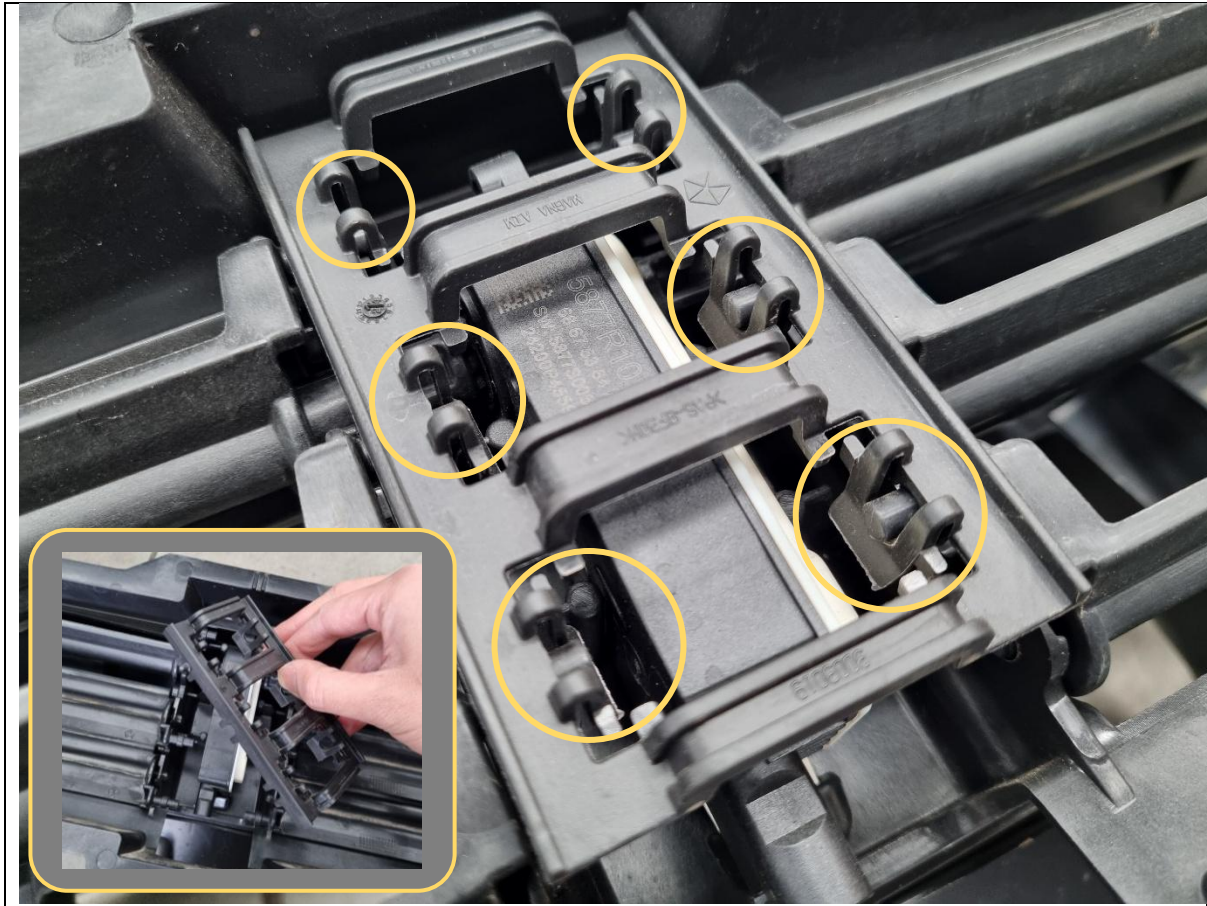

77. The motor from the shutter assembly needs to be relocated into the bull bar. Use a flat blade screwdriver to pry off the rear motor cover in 6x locations, as shown.

TOOLS REQUIRED

Flat blade screwdriver
or
Trim tool

FASTENERS

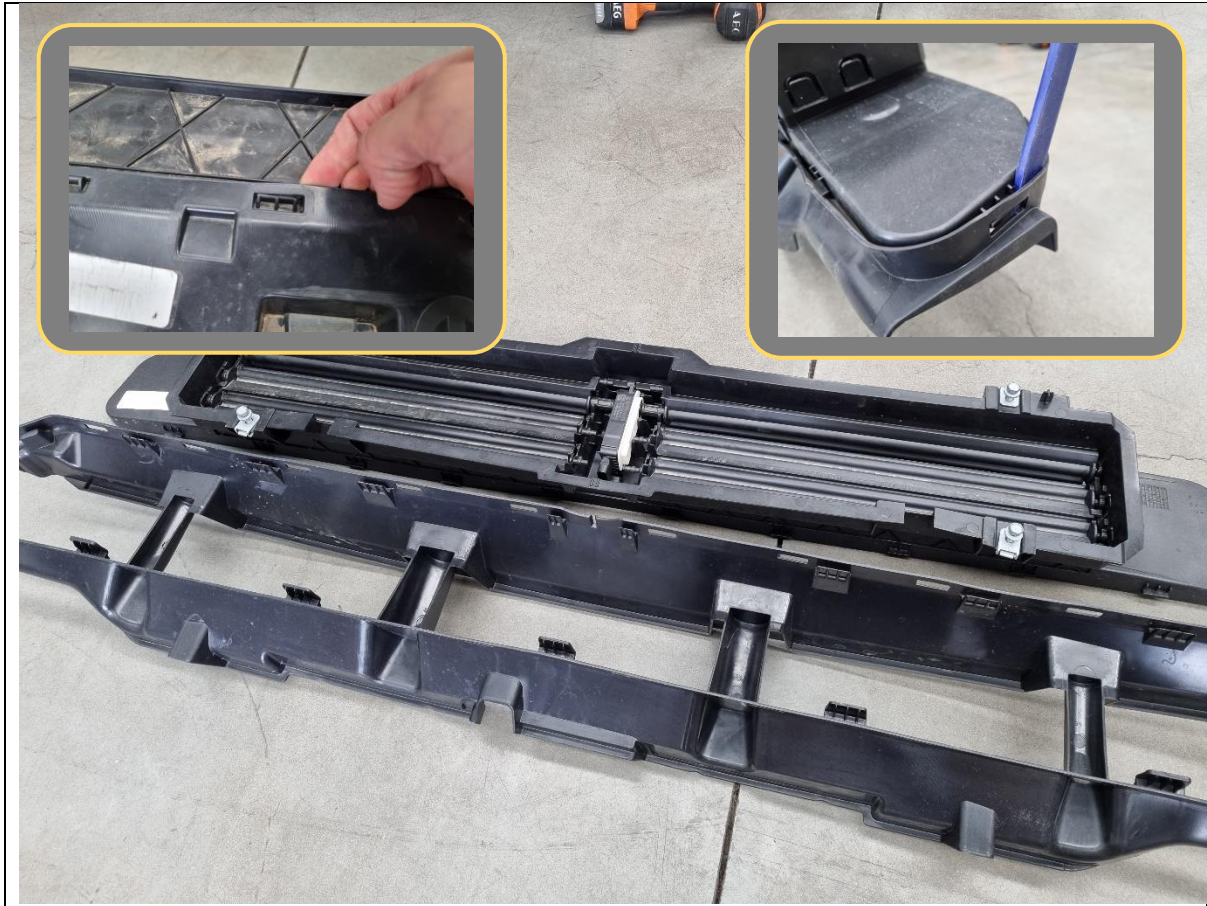

78. Use a flat blade screwdriver or trim tool and pry off the front plastic shroud.

TOOLS REQUIRED

Flat blade screwdriver
or
Trim tool

FASTENERS

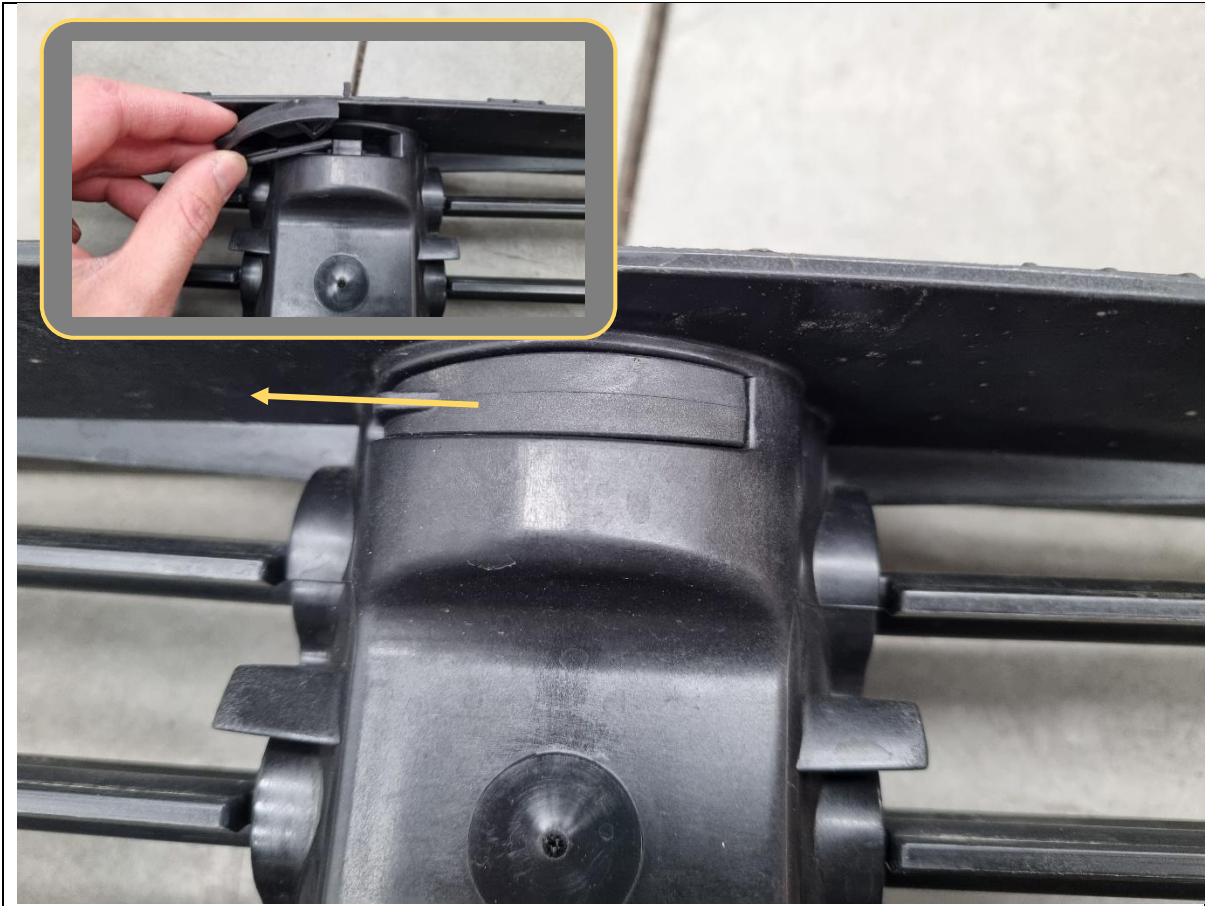

79. Push/slide out the retaining pin on the back side of the motor.

TOOLS REQUIRED

FASTENERS

2x screws (discard)



80. Carefully flex/bend the 2x shutter drive vanes that are directly connected to the motor. Start from the outer ends (see arrow in inset photo) and they should be able to pop out of the shutter assembly housing and motor spline shaft.

TOOLS REQUIRED

FASTENERS



81. With the shutter drive vanes removed, lift out the motor and set aside.

TOOLS REQUIRED

FASTENERS

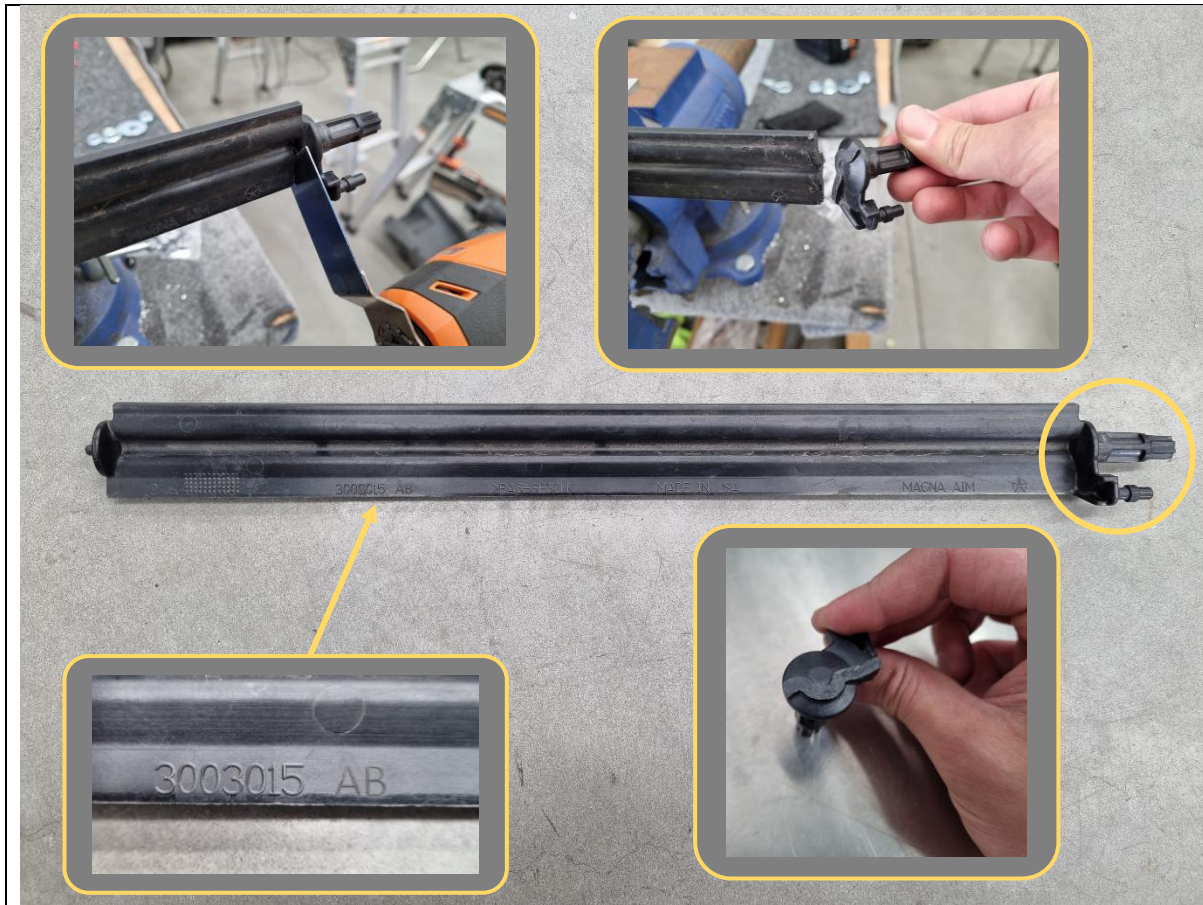

- 82. Locate the shutter drive vane with part no. 3003015.
 - 83. Use a cutting tool such as an oscillating multi tool and cut off the splined end as shown. Make the cut as flush as possible with the circular section. File/sand smooth if required.
- The rest of the drive vane can be discarded.

TOOLS REQUIRED

- Safety glasses
- Air Hacksaw
or
Oscillating Multi Tool
or
Angle Grinder
or
Jigsaw

FASTENERS

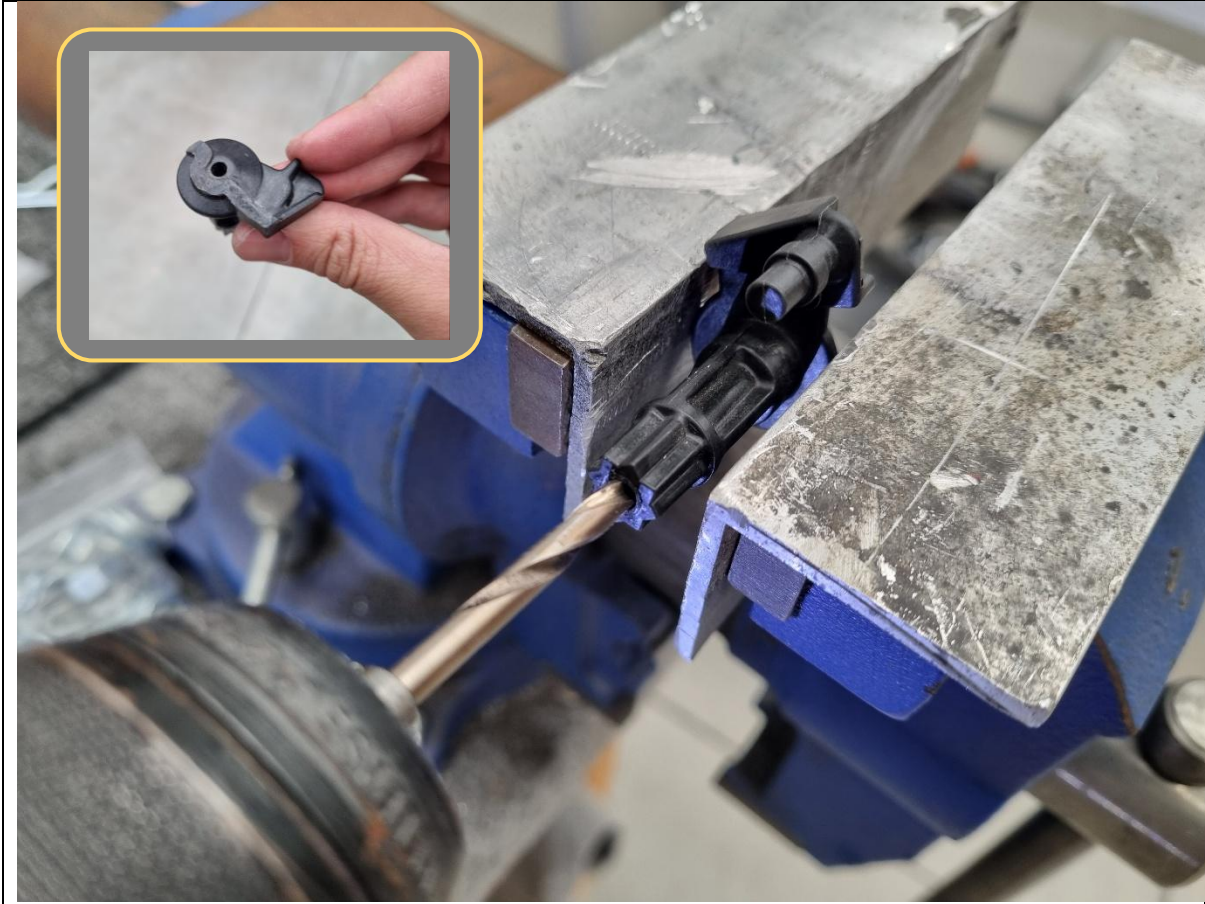

84. Use the hole at the end of the spline as a guide and drill a 4mm hole through the entire trimmed drive vane.

TOOLS REQUIRED

Electric drill
4mm drill bit

FASTENERS

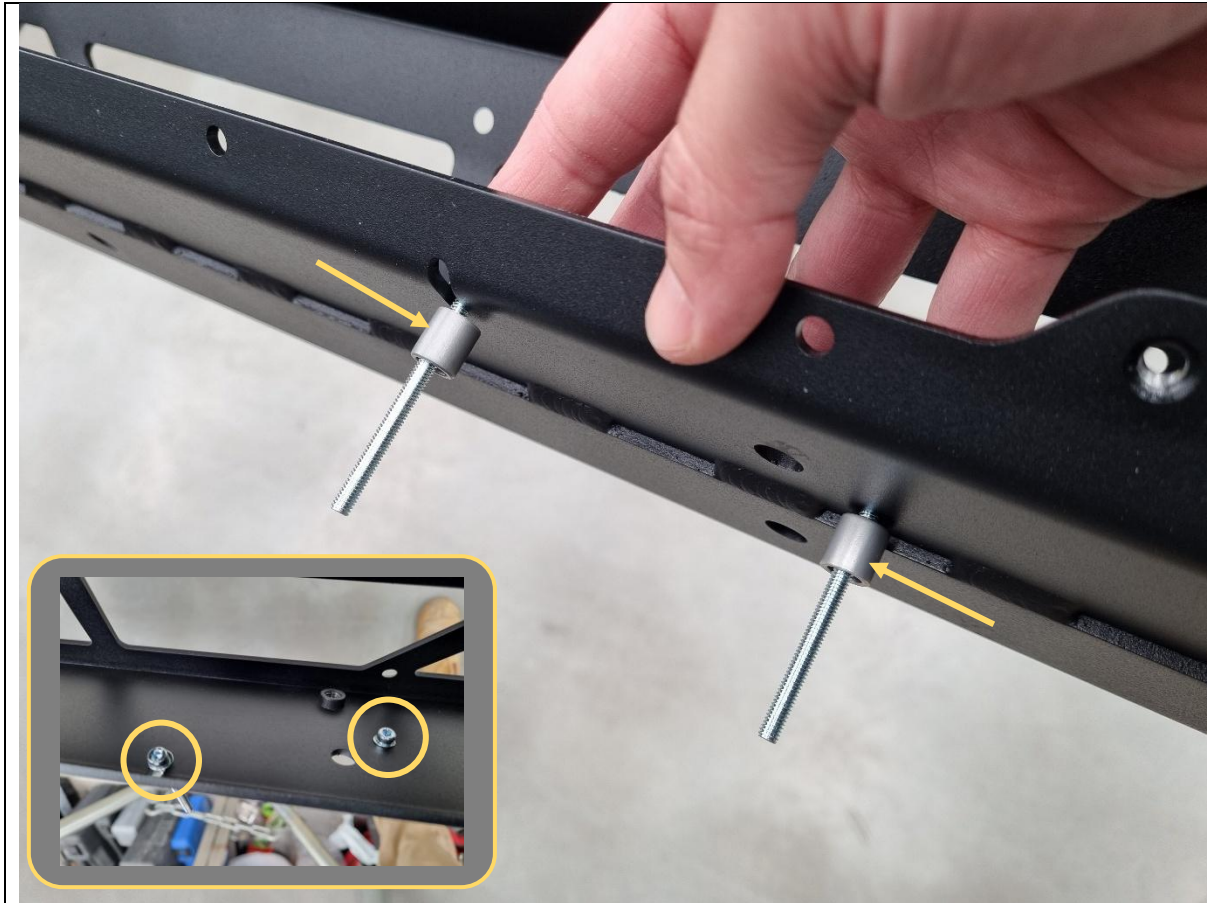

The steps on the next few pages are easiest to do all in one go, otherwise it will be even more fiddly. Read ahead and familiarise yourself with the procedure.

- 85. Locate the 2x small holes/slots in the centre section of the bull bar and place in 2x M4x50 socket head cap screws and washers as shown.
- 86. Place 2x 11mm length crush tubes (shorter type supplied) onto the bolts.

TOOLS REQUIRED

FASTENERS

- 2x M4x50 socket head cap screw
- 2x M4 flat washer
- 2x 11mm crush tube



- 87. Place 1x M4x65 socket head cap screw and P-0510 washer plate in the splined hole of the shutter motor, as shown in inset photo.
- 88. Feed the motor with bolt onto the 2x bolts in the bull bar, as shown in main photo.

TOOLS REQUIRED

Flat blade screwdriver

FASTENERS

1x M4x65 socket head cap screw
1x P-0510 washer plate

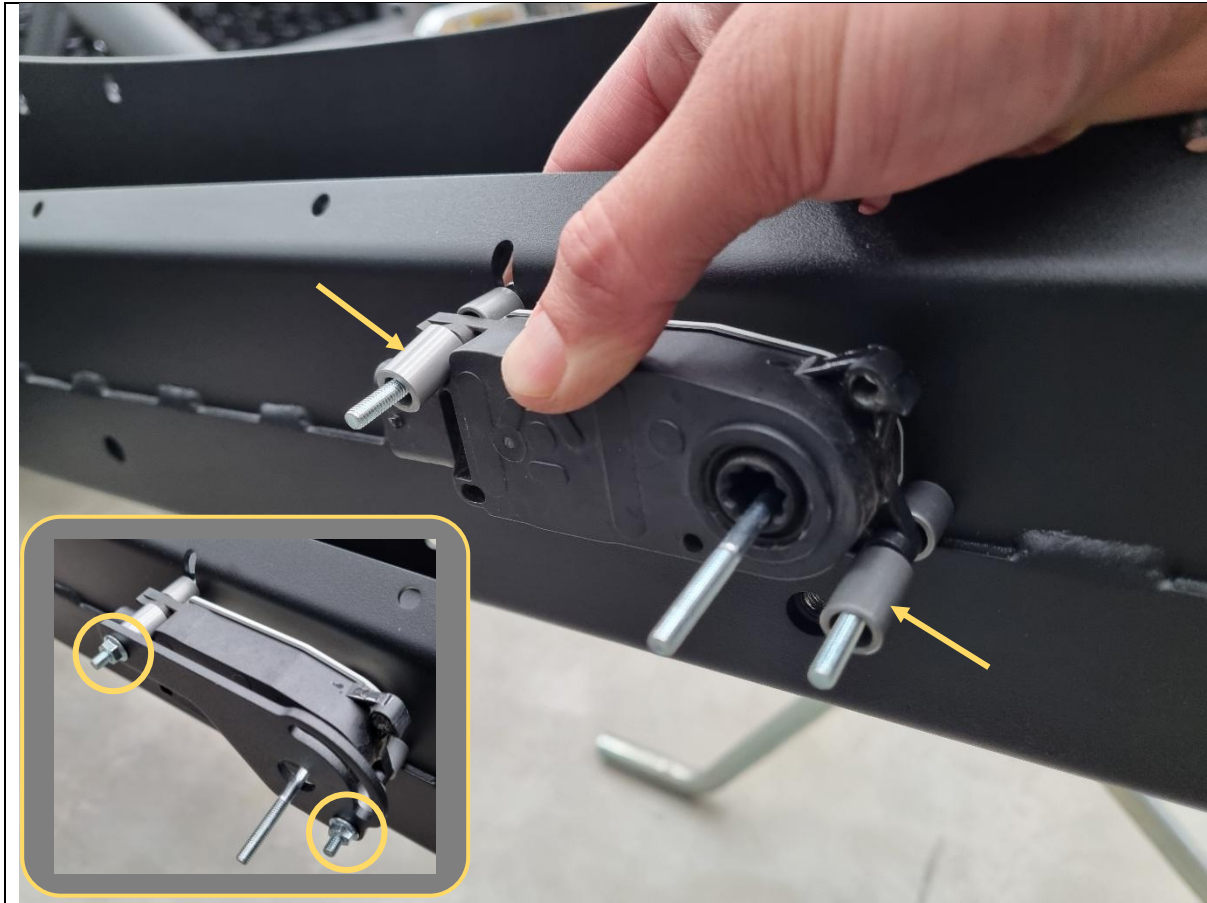

89. Fit the longer 15mm crush tubes onto the ends of the 2x main bolts.

90. Fit the P-0509 shutter motor relocation plate onto the bolts, then loosely secure with M4 flange nuts.

Leave bolts finger tight for now.

TOOLS REQUIRED

FASTENERS

2x M4 flange nut

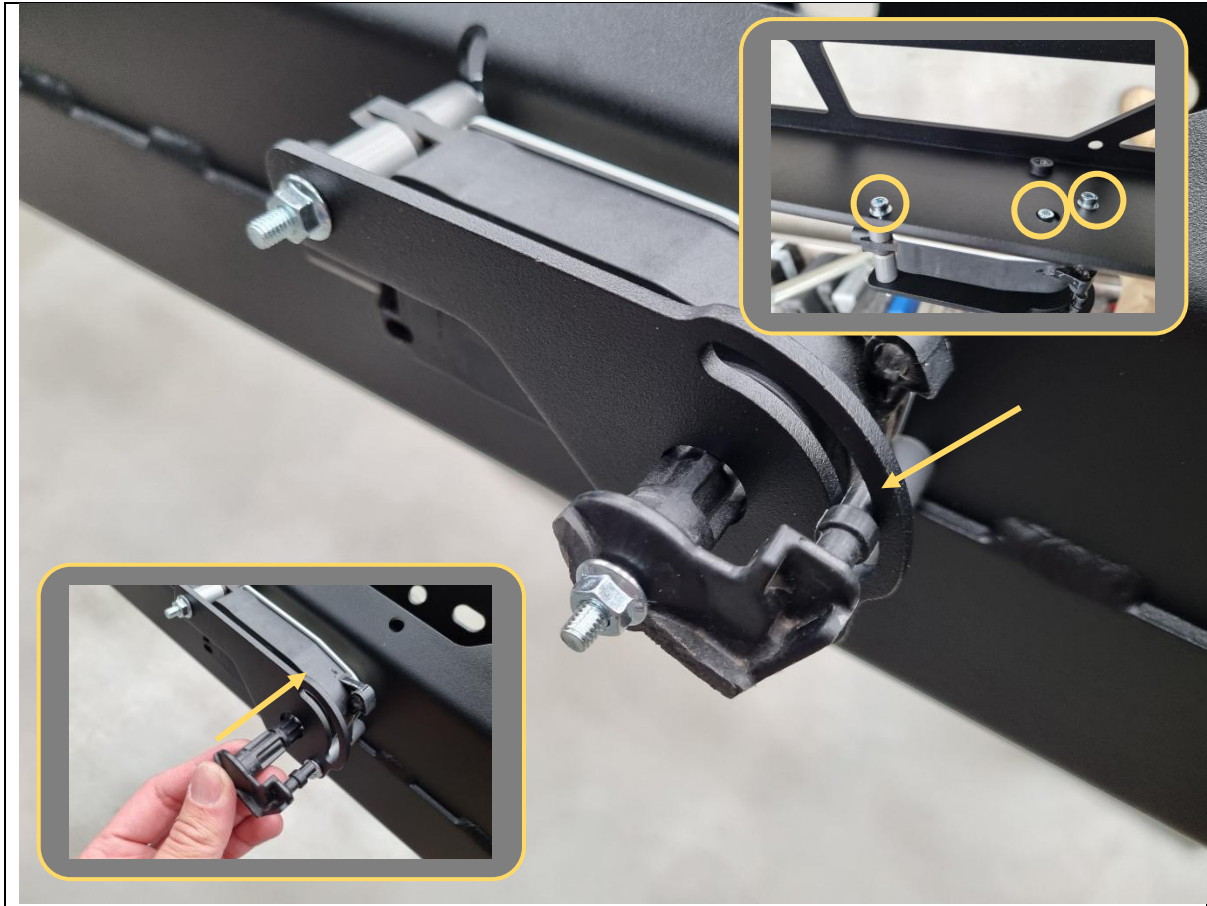

91. Insert the modified drive vane into the spline shaft of the motor. Ensure it fully goes in and the locating pin is in the curved slot on the P-0509 plate.
92. Fully tighten all 3x M4 bolts.

TOOLS REQUIRED

3mm hex/Allen key

FASTENERS



93. Fit the P-0488 light bar mesh infill to the inside of bar, and secure to the front face with 7x M6x12 black countersunk bolts and flange nuts.

TOOLS REQUIRED

4mm hex/Allen key

FASTENERS

7x M6x12 black countersunk bolt
7x M6 flange nut



94. If fitting an integrated light bar, do so now.

This bar is designed to fit the Offroad Animal 32-inch light bar. If fitting this light bar, secure with M6 fasteners supplied with the light.

This bar can accommodate most other "30-32inch" size single row light bars.

TOOLS REQUIRED

Supplied with accessories

FASTENERS

Supplied with accessories



95. Fit 10x M6 cage nuts into the rectangular slots in bottom of the bull bar wing (5x per side).

Use a small flat blade screwdriver to push the edge of the cage to engage with the slot to aid fitting.

TOOLS REQUIRED

Flat blade screwdriver

FASTENERS

10x M6 cage nut



Apply primer to both bull bar and sensor holders

96. Clean the mounting surfaces of the 6x F-0030 parking sensor holders and the corresponding mounting locations on the inside of the bull bar with isopropyl alcohol or similar and let it dry.
97. Take the 3M Primer 94 ampule from the supplied parking sensor tape kit and apply primer to all the cleaned surfaces, both on the bull bar and on the sensor holders.

TOOLS REQUIRED

Isopropyl alcohol
Clean rag

FASTENERS

3M Primer 94



Allow at least 5 minutes for the primer to chemically bond to the surfaces before applying tape.

- 98. Apply supplied 3M VHB tape from the universal parking sensor tape kit to the F-0030 parking sensor holders as shown.
- 99. Clip the parking sensors into the sensor holders. Press in firmly to ensure the tabs on both sides of the sensor are seated in the sensor holder.

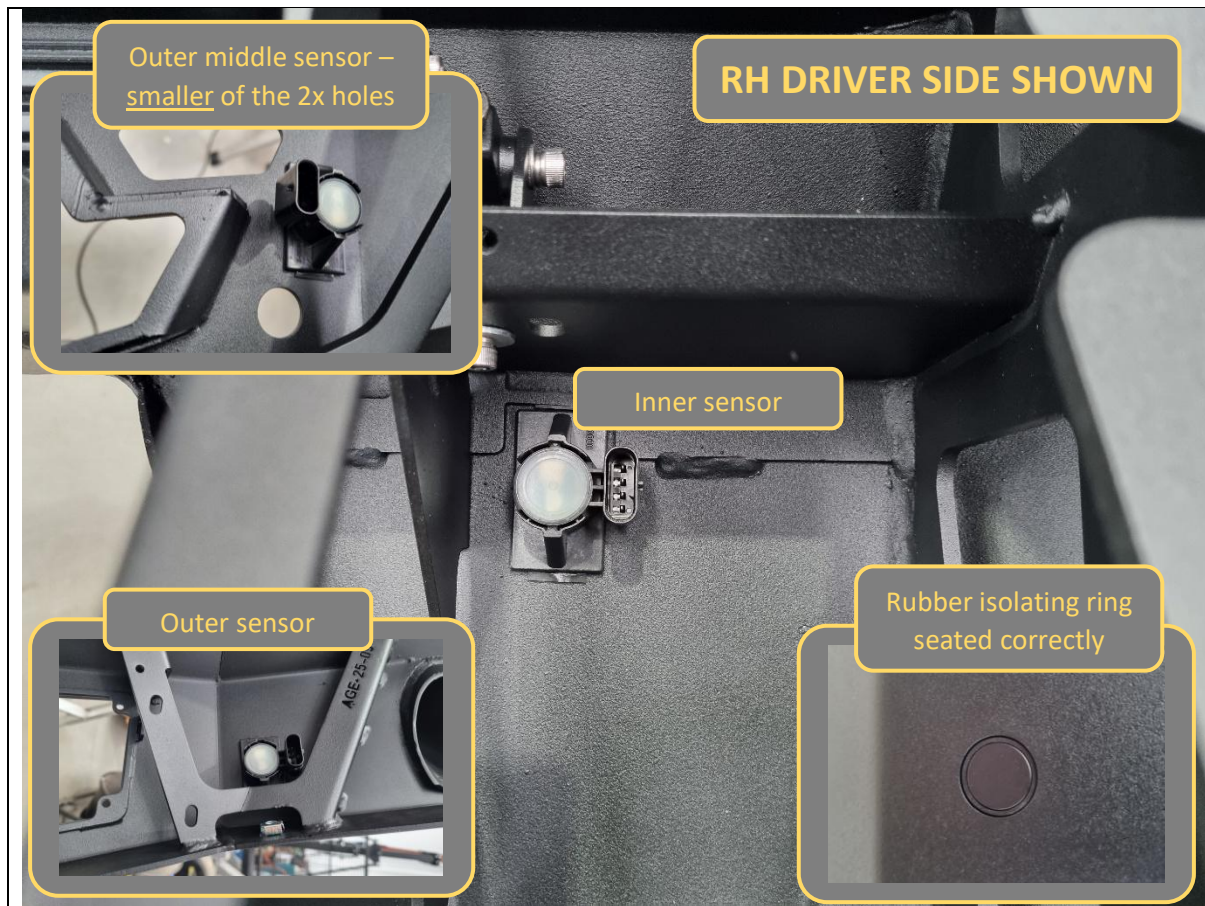

100. Remove the backing film off the tape on the parking sensor holders (use utility knife or 90 degree pick to assist), then fit to their corresponding positions inside the bull bar.

Ensure the rubber isolating ring of the parking sensor fits through the hole in the bar and is not wedged in incorrectly.

Ensure the sensor plug orientation matches the installation in the factory bumper.

101. Add a pea-sized blob of automotive adhesive sealant (we recommended Sikaflex 227) over the sensor holders and inside face of bar to hold to ensure the tape holds position.

TOOLS REQUIRED

- Utility knife
- Automotive adhesive sealant (eg. Sikaflex)

FASTENERS



- 102. **'Laramie Sport', 'Express Black Edition' and 'Rebel' models only.** Fit the marker lamps with rubber grommet through the hole in the bull bar wing, below the outer middle parking sensor.
- 103. **'Laramie Sport' 'Express Black Edition' and 'Rebel' models only.** Clip in the F-0037 retaining ring on the back of the lamp to fully secure the lamp in the bullbar (see bottom inset photo).

TOOLS REQUIRED

FASTENERS

2x F-0037 retaining rings



104. **'Limited' models only.** Fit the 20mm plastic blanking plug through the hole in the bull bar wing instead.

TOOLS REQUIRED

FASTENERS

2x 20mm plastic blanking plug



105. **'limited' models only.** Prepare the side radar brackets and identify LH and RH as shown.

TOOLS REQUIRED

FASTENERS

1x M12 flange nut



'LIMITED' MODEL ONLY

- 106. **'Limited' models only.** Cut and split the 2x tape strips into 6x equal lengths (ie. divide each strip into thirds).
- 107. **'Limited' models only.** Apply tape to the top and bottom of each side radar, as shown.

TOOLS REQUIRED

Scissors
or
Utility knife

FASTENERS

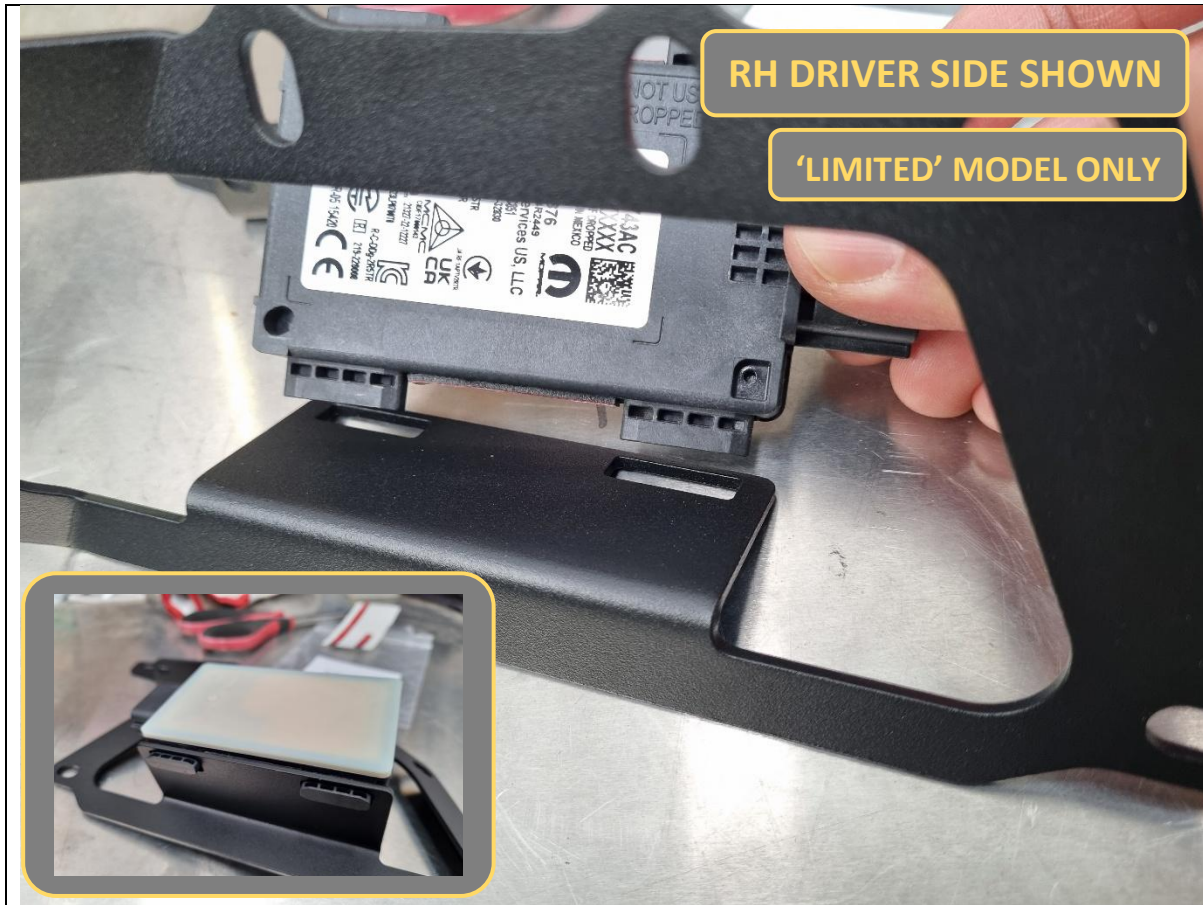

108. **'Limited' models only.** Remove the backing film off the tape on the side radar, then insert it onto the radar mount bracket as shown.

Ensure the radar orientation matches the images exactly.

TOOLS REQUIRED

Utility knife

FASTENERS

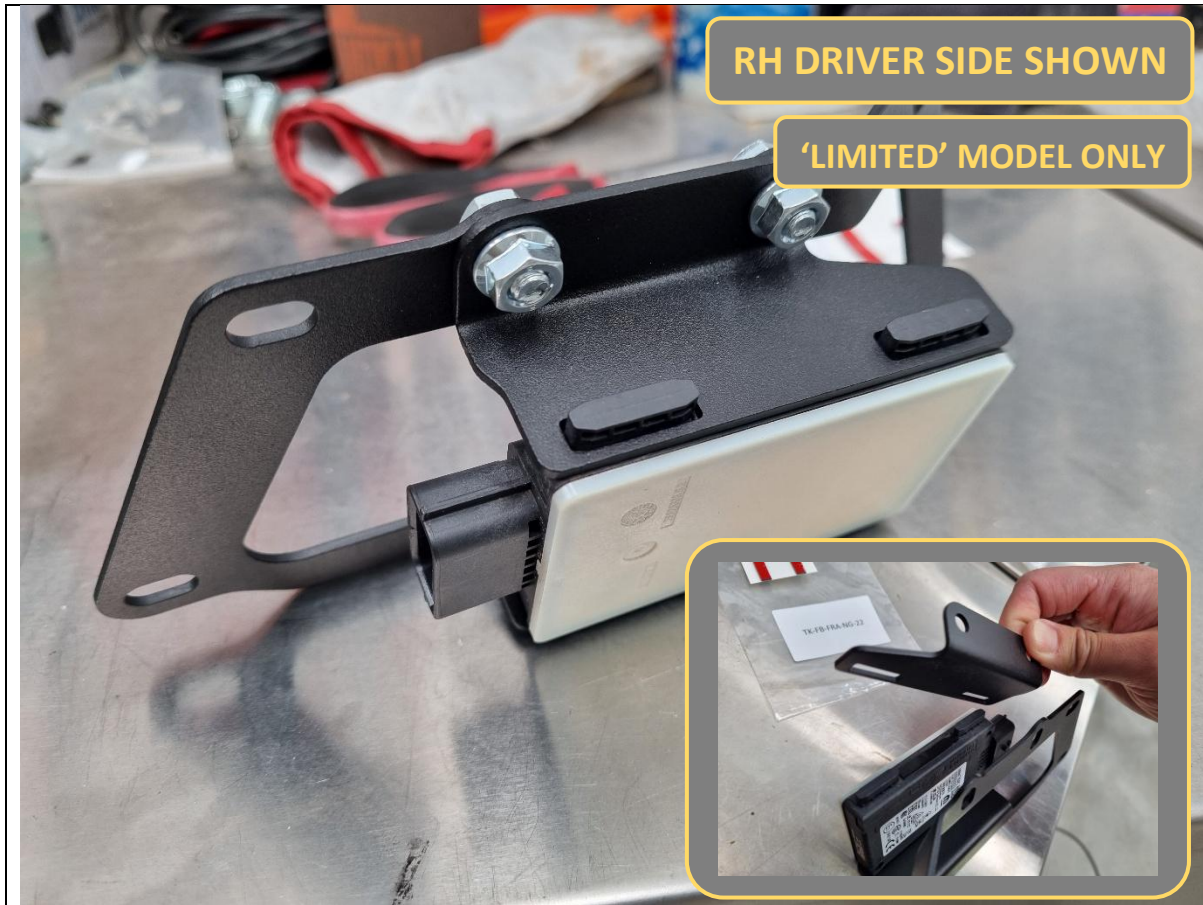

- 109. **'Limited' models only.** Take the radar clamp bracket and fit it on top of the radar.
- 110. **'Limited' models only.** Press down firmly to ensure radar is clamped in and can't move around, then secure clamp bracket to main mount bracket with 2x M6x12 hex bolts, washers and flange nuts.
- 111. **'Limited' models only.** Repeat the process for both side radars.

TOOLS REQUIRED

10mm socket/spanner

FASTENERS

4x M6x12 hex bolt
4x M6 flat washer
4x M6 flange nut

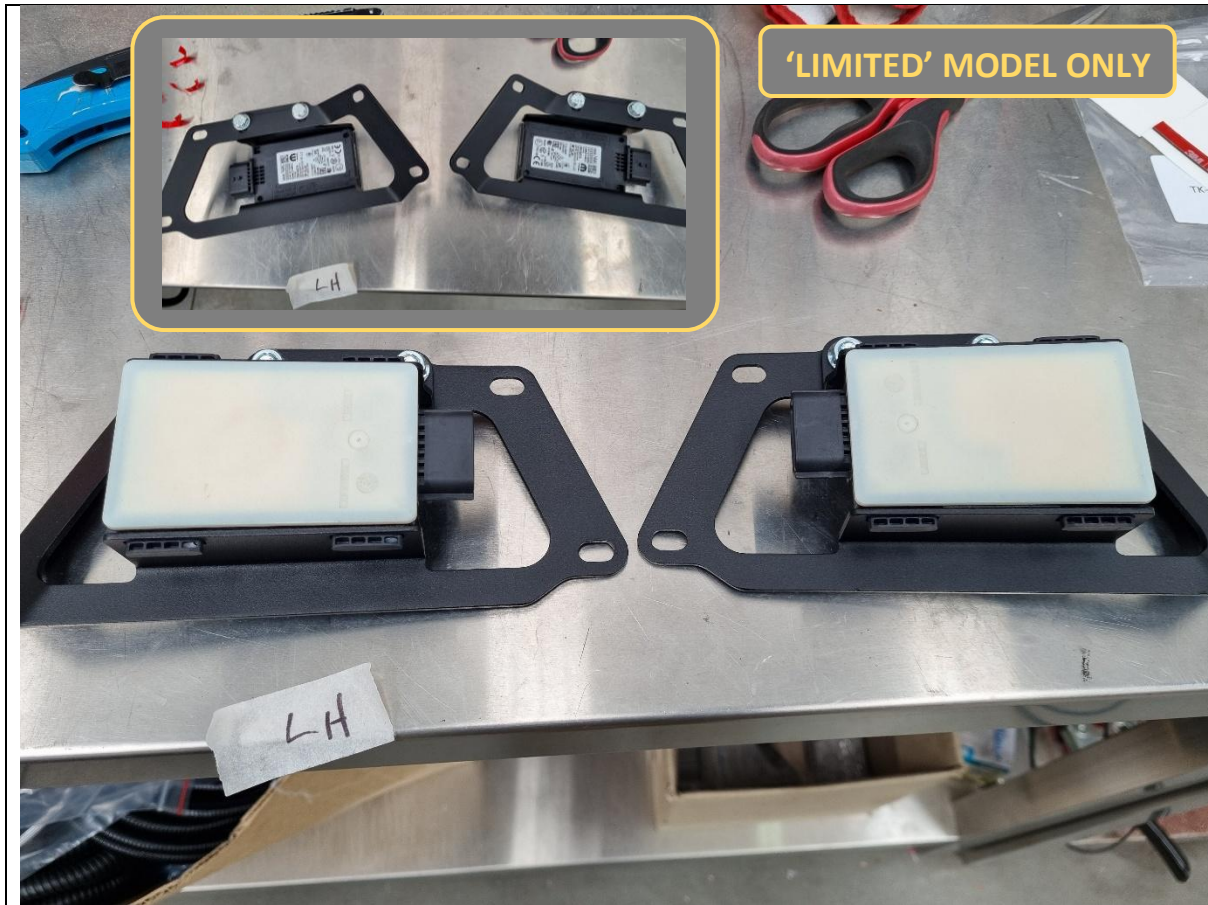

112. **'Limited' models only.** Side radar assemblies should now look like this.

TOOLS REQUIRED

FASTENERS



- 113. **'Limited' models only.** Fit the side radar assemblies into each side of the bull bar.
- 114. **'Limited' models only.** Secure each mount bracket to the inside brace of the bull bar with 4x M6x12 hex bolts, flat washers and flange nuts.

TOOLS REQUIRED

10mm socket/spanner

FASTENERS

8x M6x12 hex bolt
8x M6 flat washer
8x M6 flange nut



115. Route the bumper harness through the cutouts in the top section of the bull bar, starting from the LH and routing to the RH.

TOOLS REQUIRED

FASTENERS

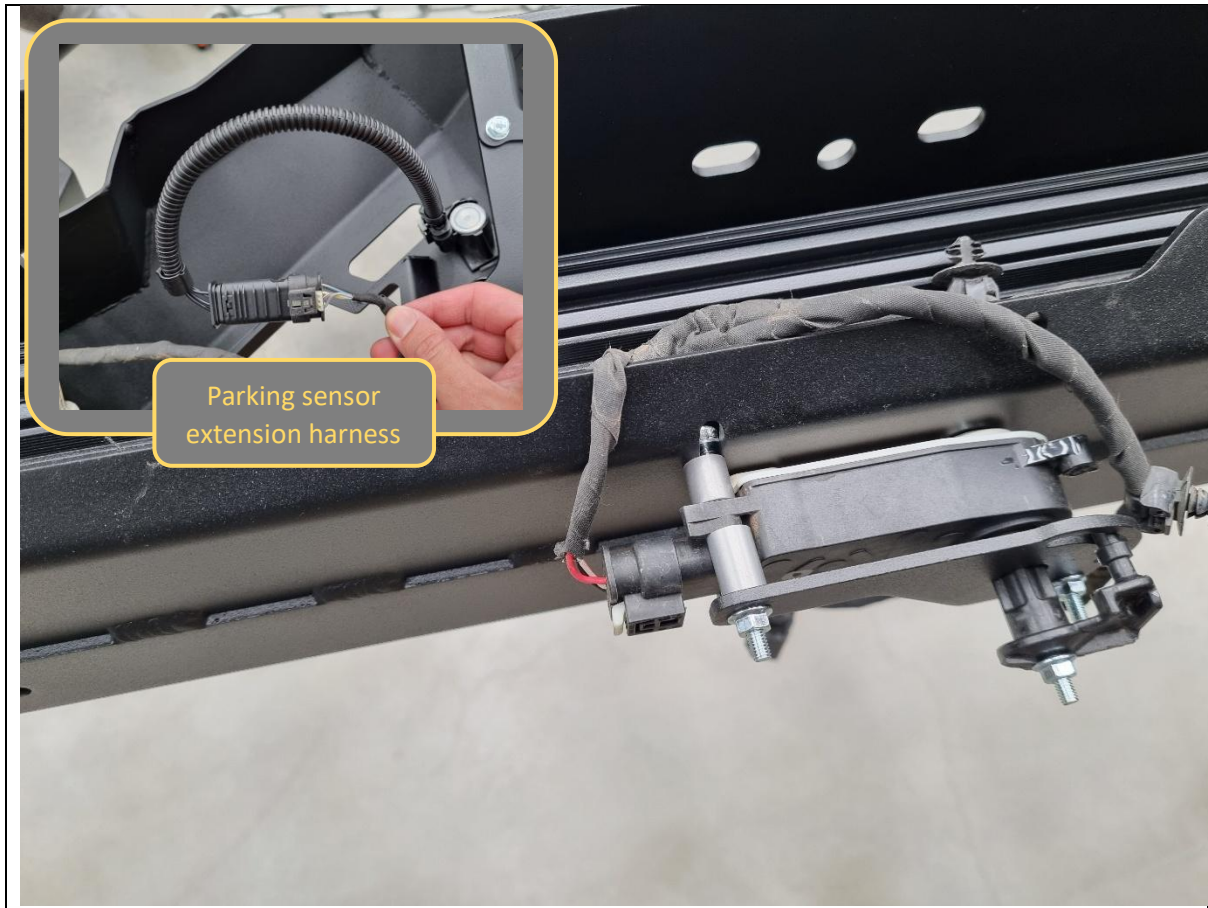

Parking sensor extension harness

- 116. Plug in the shutter motor in the centre of the bar.
- 117. Plug in the parking sensors.
- 118. The cables for the 4x outer parking sensors are not long enough. Use the supplied PSE14 parking sensor extension harnesses.
- 119. If equipped, connect the marker lamps now as well (not pictured).

TOOLS REQUIRED

FASTENERS

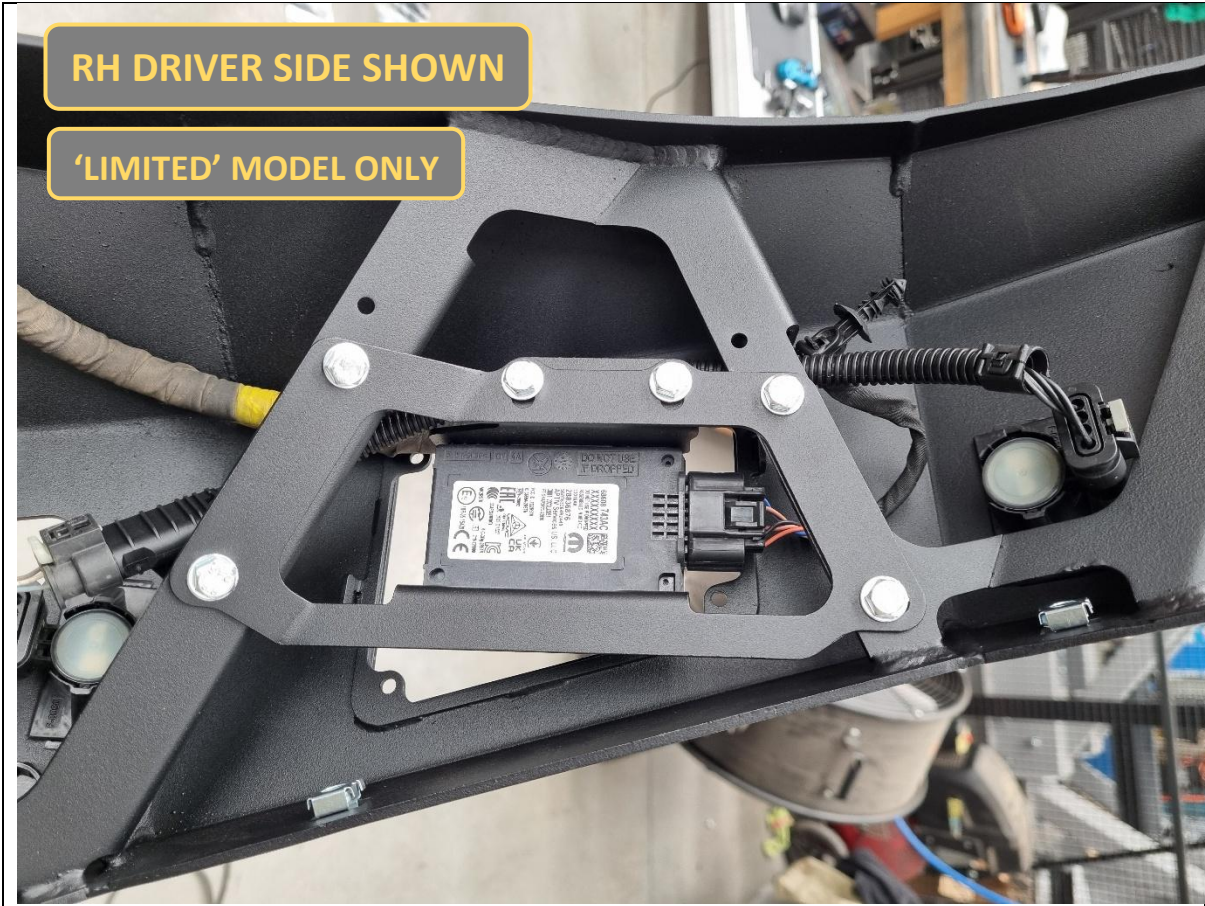

120. 'Limited' models only. Plug in the side radars.

TOOLS REQUIRED

FASTENERS



TORO BARS ONLY

Nut and washer on back face

121. **Toro only.** Fit the supplied indicator repeater lamps to the wing mesh panels. Use the double-sided tape pad, then secure each indicator with 2x M3x12 pan head screws, flat washers and hex nuts.

TOOLS REQUIRED
Phillips head screwdriver
5.5mm socket/spanner

FASTENERS
4x M3x12 pan head screw
4x M3 flat washer
4x M3 hex nut

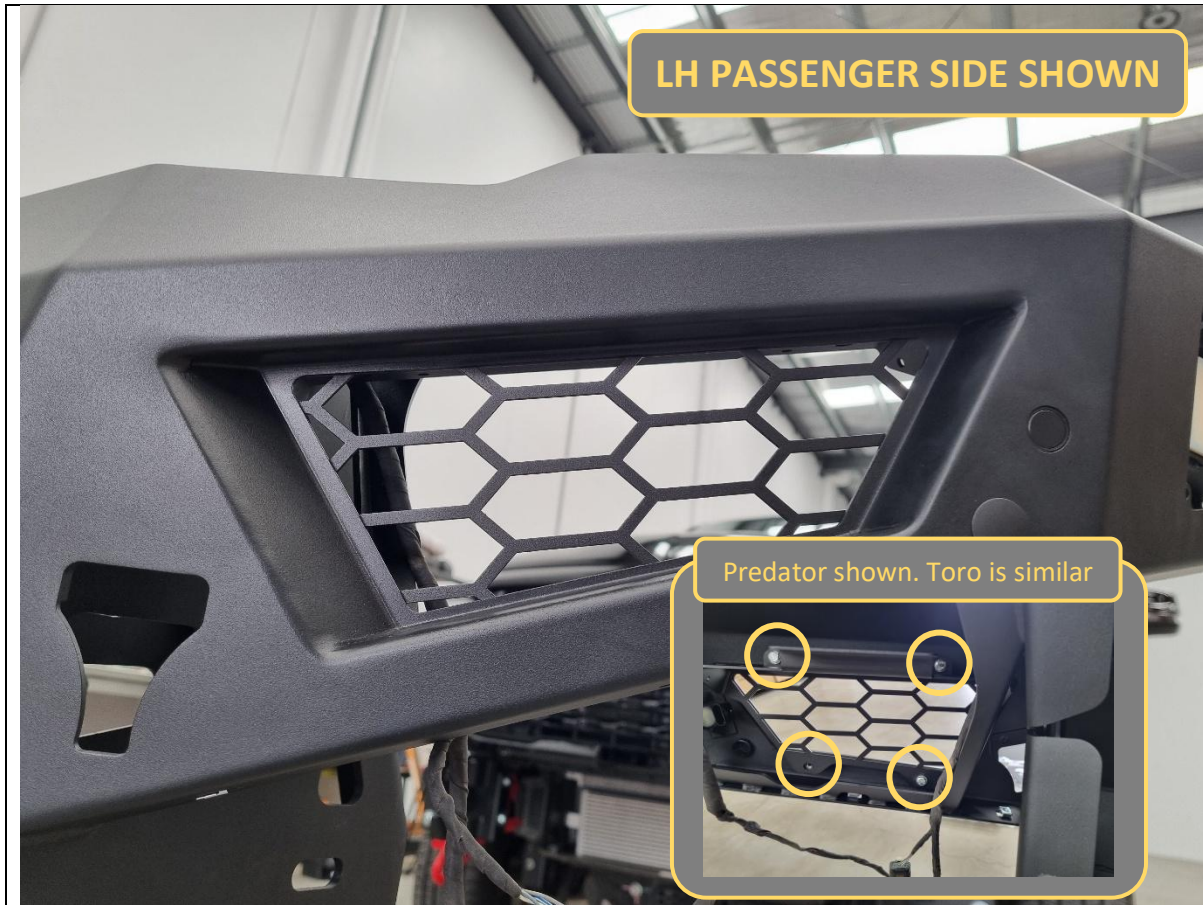

122. Fit the wing meshes to the inside of the bull bar wings and secure each one to the embedded nuts with 4x M6x12 hex bolts and flat washers.

TOOLS REQUIRED

10mm socket/spanner

FASTENERS

8x M6x12 hex bolt
8x M6 flat washer

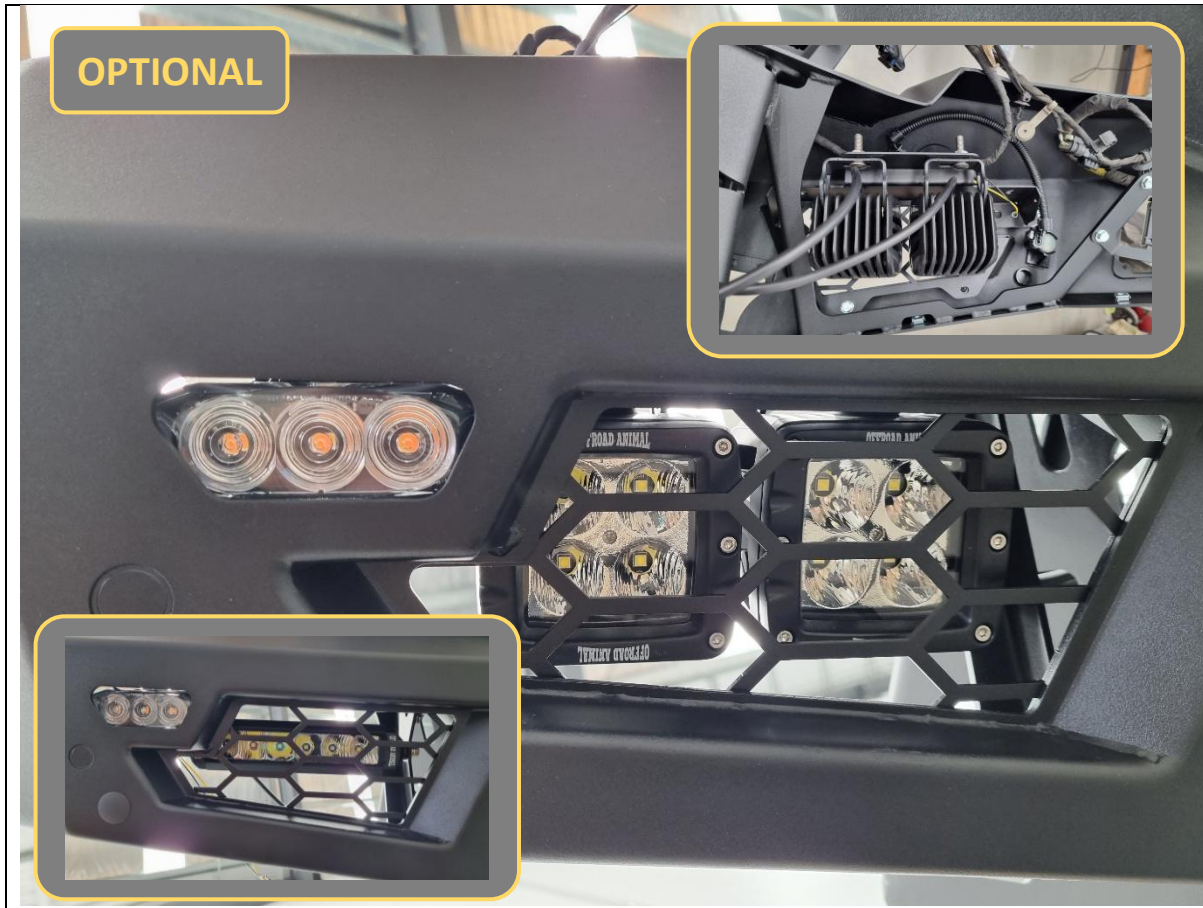

123. **Optional.** Each wing mesh can support up to 2x cube lights or 1x 8" single row light bar. Fit these now to the wing meshes.

Otherwise, this area can be left blank, or have fog lights fitted (outlined in next steps).

TOOLS REQUIRED

Refer to instructions supplied with lights

FASTENERS

Supplied with lights



124. The supplied fog light brackets are compatible with 'Type A' fog lights. Fit these together now with 4x M6x16 black button head bolts, black washers and flange nuts, as shown.

TOOLS REQUIRED

4mm hex/Allen key

FASTENERS

8x M6x16 black button head
8x M6 black washer
8x M6 flange nut

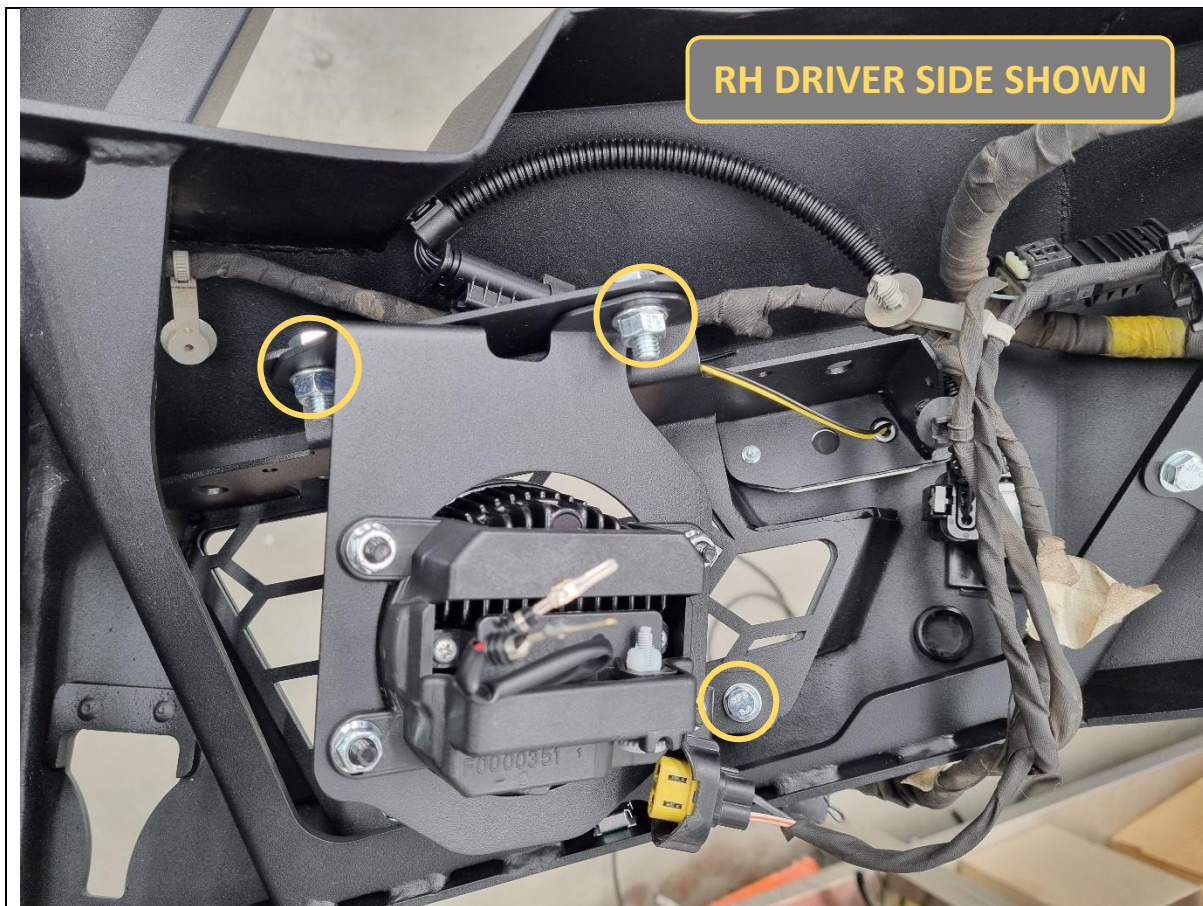

- 125. Remove the bottom outer M6x12 hex bolt and washer holding the wing mesh.
- 126. Fit the fog light and bracket to the wing mesh.
- 127. Secure at the top with 2x M8x20 hex bolts, washers and flat washers. Re-secure at the bottom using the same M6x12 hex bolt and washer.
- 128. Repeat for both sides.

TOOLS REQUIRED

- 10mm socket/spanner
- 13mm socket/spanner

FASTENERS

- 4x M8x20 hex bolt
- 4x M8 flat washer
- 4x M8 flange nut



129. Fit on the plug supplied with the fog light. The wire pin-out on the bumper harness side should be as follows:
- a. Ground = black
 - b. +12V Fog Signal RH = white with red trace
 - c. +12V Fog Signal LH = white with yellow trace

Confirm with a test light.

TOOLS REQUIRED

FASTENERS



130. If fitting driving lights to this bar, this is also the most convenient time to do so. It is still possible later, but it is more difficult.

Note: This vehicle uses CAN bus for the headlight signals. Offroad Animal can supply a module (sold separately) to connect driving lights to be switched on with high beams.

TOOLS REQUIRED

Supplied with accessories

FASTENERS

Supplied with accessories



- 131. Fit the pair of pan braces to the back of the light bar mounting area in the bull bar.
- 132. Secure the bottom of each pan brace to the embedded nuts in the bull bar with 2x M6x16 black button head bolts and black washers.
- 133. Secure the top of each pan brace to the bull bar with 2x M6x16 black button head bolts, black washers and flange nuts.

TOOLS REQUIRED

4mm hex/Allen key

FASTENERS

4x M6x16 black button head
4x M6 black washer
2x M6 flange nut



134. **Predator only.** If fitting the stealth hoop, round hoop or rally hoop to this bar, this is also the most convenient time to do so. It is still possible later, but it is more difficult.

TOOLS REQUIRED

Supplied with accessories

FASTENERS

Supplied with accessories



135. Perform some cable management for the bumper harness inside the bar, using holes provided for cable ties. Ensure cables won't rub or chafe anywhere.

TOOLS REQUIRED

Side cutters

FASTENERS

Cable ties



136. Fit the side radar covers (textured face on outside) to the windows in the bull bar wings. Use 4x fir tree clips per radar cover to secure.

TOOLS REQUIRED

FASTENERS

8x fir tree clip



137. **Optional.** Fit the supplied lengths of pinch weld rubber to the top edge of the bull bar wings. Trim to length with side cutters.

This is only if you don't like seeing the necessary gap to allow relative movement between the bar and vehicle (see inset photo).

TOOLS REQUIRED

Side cutters

FASTENERS



- 138. **Toro only.** If required, fit the supplied antenna mounting brackets to the back of the bar, and secure with 2x M8x20 black button head bolts and black washers, each.
- 139. **Toro only.** Else fit the 2x M8x20 black button head bolts and black washers to the back of each bullbar upright, to protect nut threads in bar for future use.

TOOLS REQUIRED

5mm hex/Allen key

FASTENERS

4x M8x20 black button head
4x M8 black flat washer

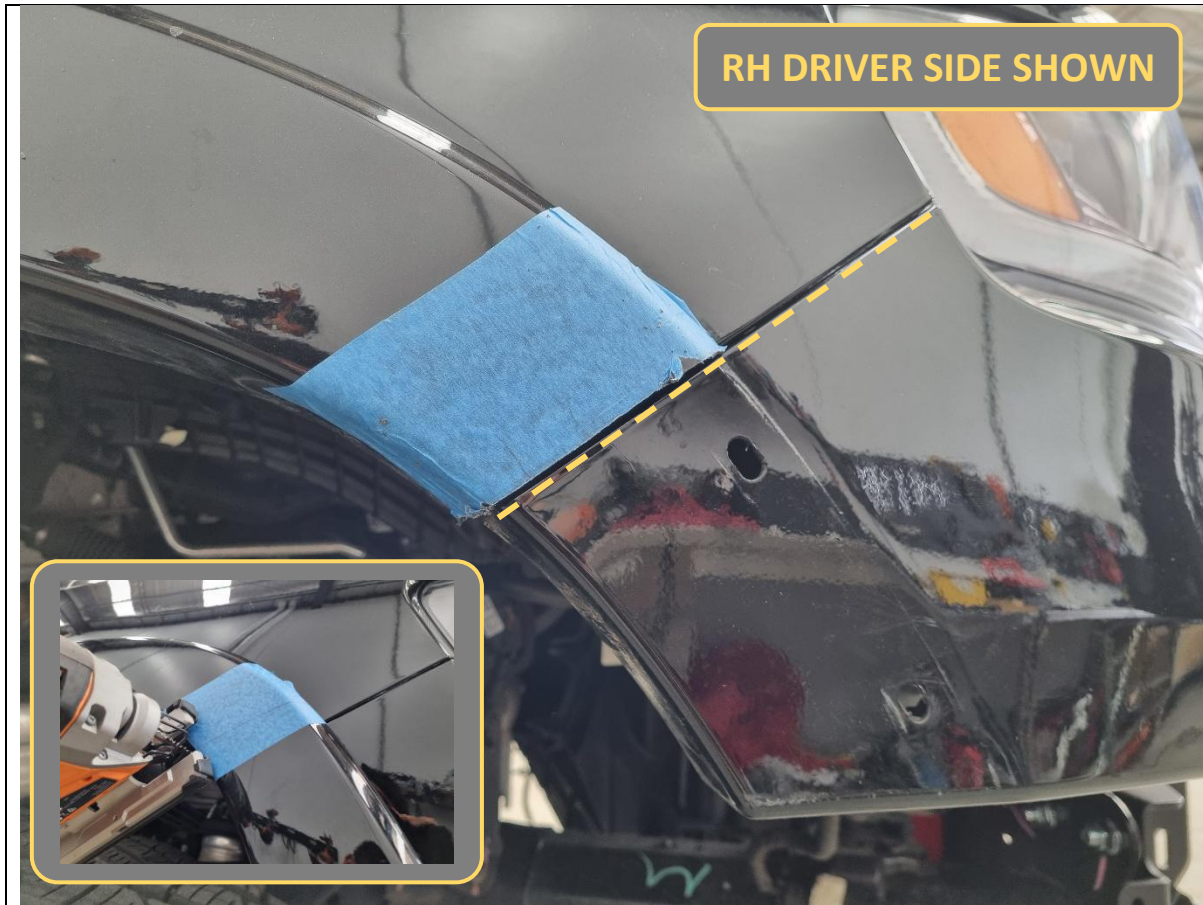

RH DRIVER SIDE SHOWN

140. Trim the flares along the marked cut line, so that the flare is perfectly flush with the quarter panel line.

You may want to make a conservative cut first and check the fitment. You don't want to overshoot and cut off too much or have the cut edge wonky.

Take care to make a clean straight cut.

141. Remove masking tape, deburr the cut edge, then re-clip flare onto vehicle.

TOOLS REQUIRED

Safety glasses

Air Hacksaw

or

Oscillating Multi Tool

or

Angle Grinder

or

Jigsaw

Deburring tool

FASTENERS

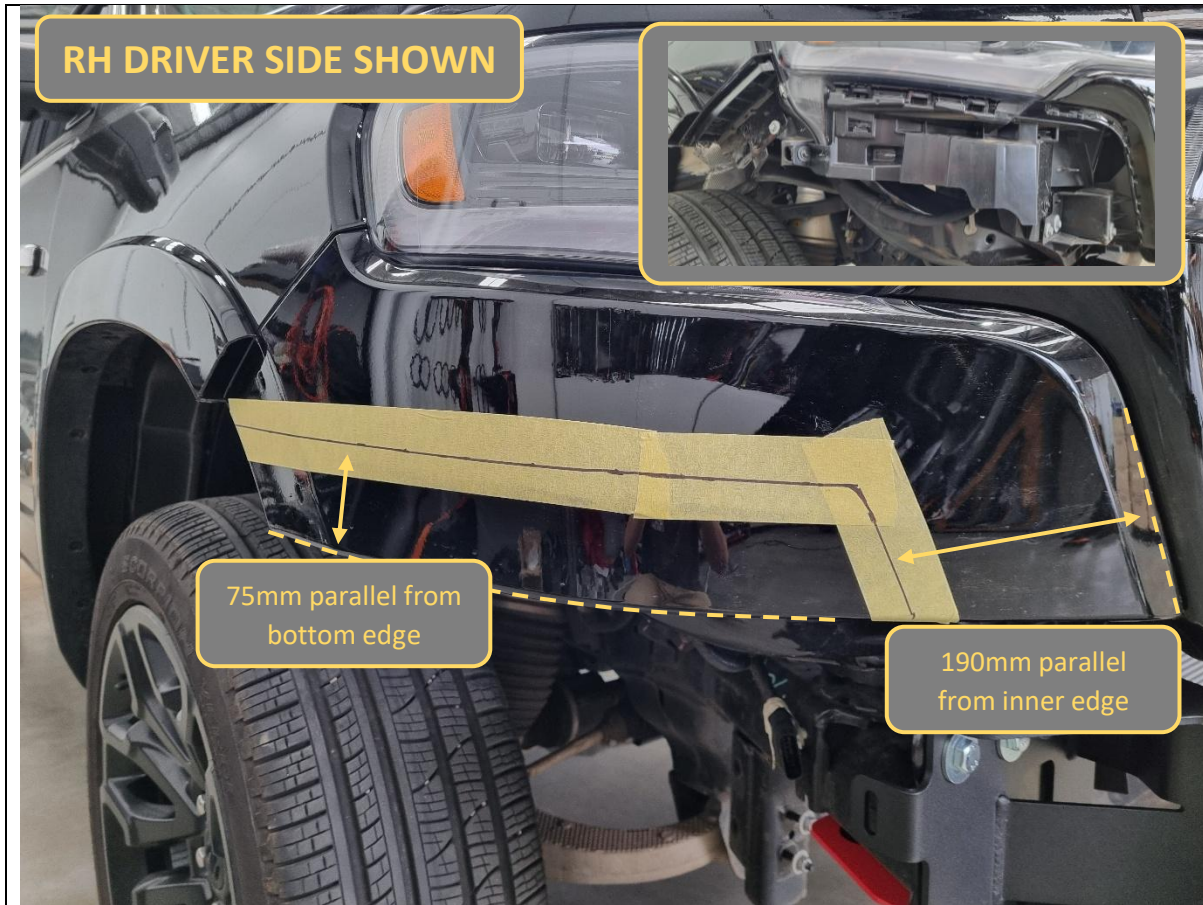

<p>The plastic bumperette needs to be trimmed now. It should have been already removed from the vehicle during bumper disassembly. If not, do it now.</p> <p>The above photo showing it on the car is just for reference.</p> <p>142. Apply masking tape and mark out a cut line as shown.</p>	<p>TOOLS REQUIRED</p> <p>Masking tape Marker pen Ruler</p>
	<p>FASTENERS</p>



- 143. Trim the bumperette along the marked cut line and discard the lower section.
- 144. Remove masking tape, deburr the cut edge, then re-clip bumperette onto vehicle.

TOOLS REQUIRED

- Safety glasses
- Air Hacksaw
or
Oscillating Multi Tool
or
Angle Grinder
or
Jigsaw
- Deburring tool

FASTENERS



<p>Trimmed panel and flare should now look like this.</p> <p>145. Remember to re-install the 10mm hex bolt that was removed from Step 11.</p>	<p>TOOLS REQUIRED</p> <p>10mm socket/spanner</p>
	<p>FASTENERS</p> <p>2x factory 10mm hex bolt</p>

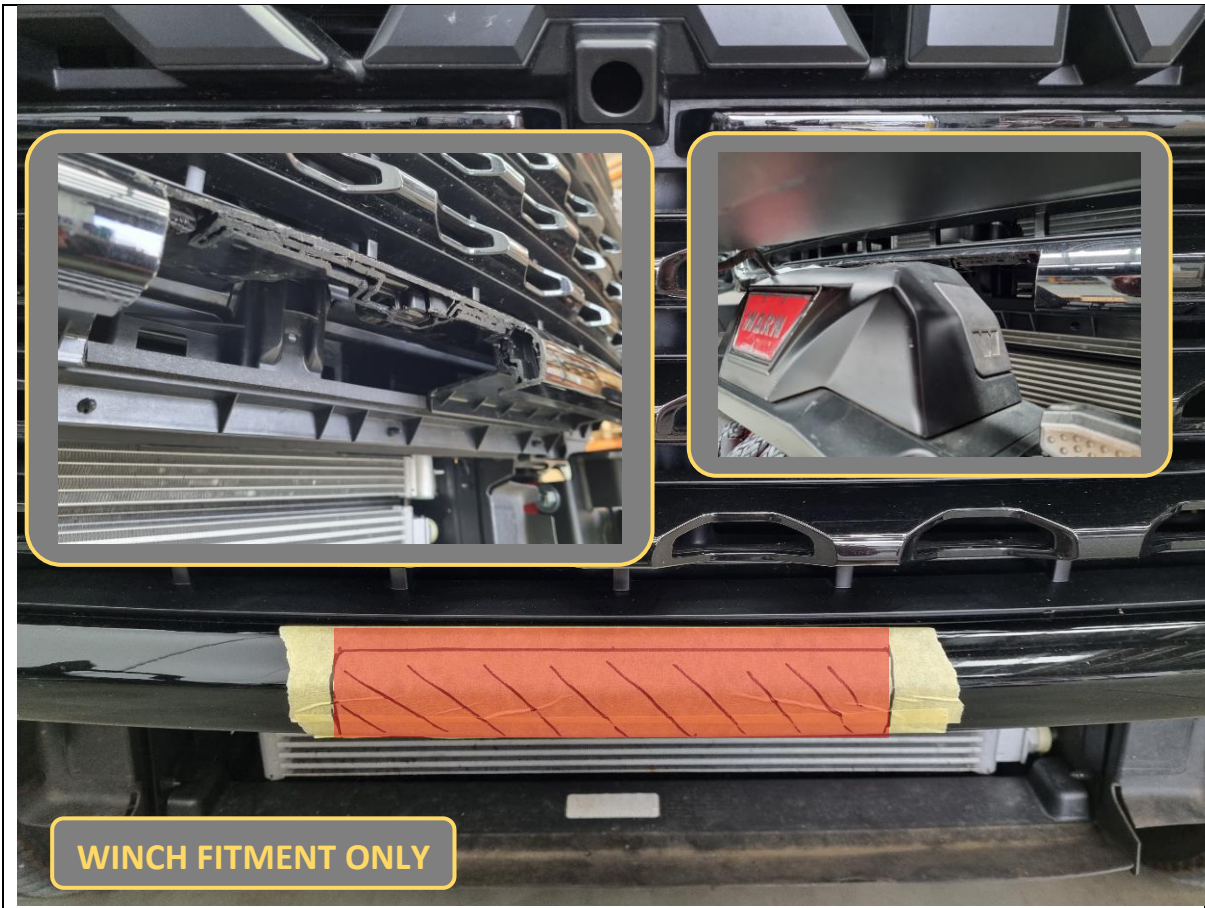

WINCH FITMENT ONLY

146. If you are going to be fitting a winch that has a top mounted control box, or is taller than 225mm in foot down configuration, you will need to trim the bottom of the grille.

e.g. If your winch is 245mm tall, you will need to cut 20mm off the bottom of the grille.

147. Measure your winch to determine how wide of a cut and where on the grille you need to cut, then apply masking tape to the grille to protect the paintwork and trim the grille.

Cut all the way up to the join line with the mesh section.

148. Remove masking tape and deburr along trimmed edges.

TOOLS REQUIRED

Masking tape
Marker pen
Ruler

Safety glasses

Air Hacksaw
or
Oscillating Multi Tool
or
Angle Grinder
or
Jigsaw

Deburring tool

FASTENERS



149. Rebel grille is a different shape, but if you need to trim anything it would be the lower mesh section.

You can safely trim off all the honeycomb mesh in the lower section since the bull bar will cover it.

TOOLS REQUIRED

FASTENERS

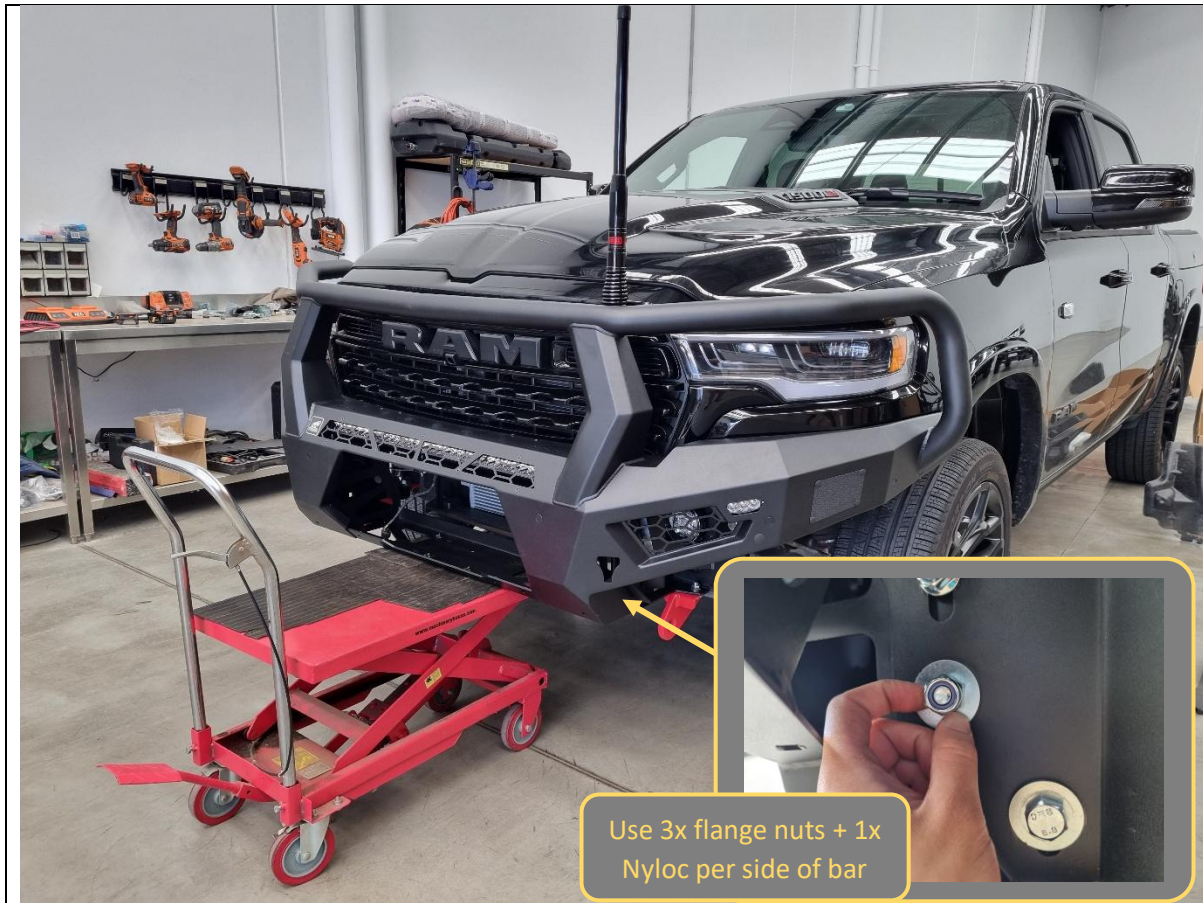

150. The bullbar is now finally ready to go onto the vehicle. With assistance, either from another person or a lifting trolley, lift the bar onto the mounts on the vehicle.

151. Secure the bar to the mounts with 8x M12x30 bolts, heavy-duty washers and Nyloc + flange nuts. Leave finger tight at this stage.

Note: Use a washer on both bolt and nut side for the Nyloc nut. 1x Nyloc required per side of the bar. 1x washer on the bolt side is all that is required with flange nuts.

TOOLS REQUIRED

Lifting trolley

FASTENERS

8x M12x30 hex bolt
10x M12 heavy duty washer
2x M12 Nyloc nut
6x M12 flange nut

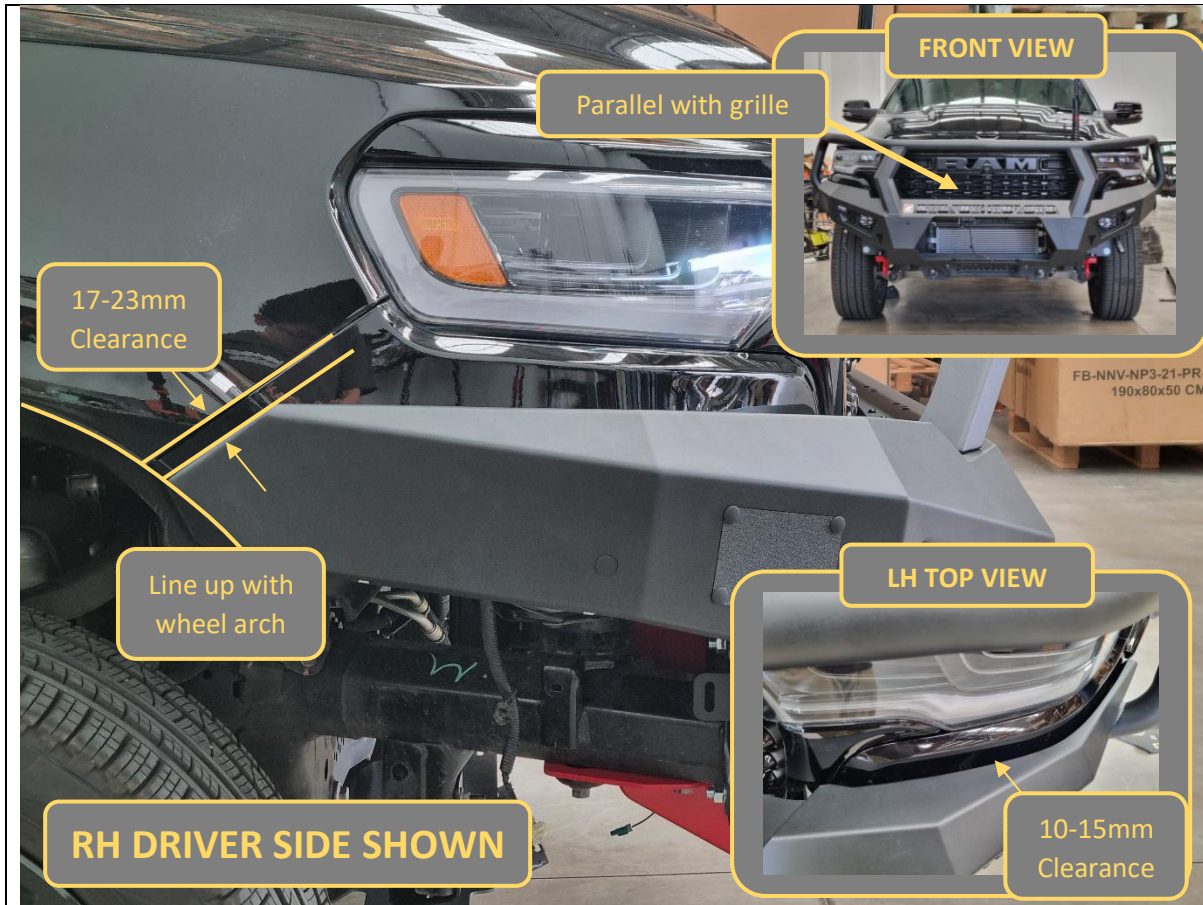

152. With assistance, from another person, align the bar with the edges of the vehicle. Adjust such that the clearances are neat, and the bar is symmetric left/right on the vehicle.

Front view: The bar should sit horizontally level and parallel with the grille.

Side view: The end of the bar wing should be in line with the wheel arch liner. The back of the wing should be parallel to the quarter panel, with 17-23mm clearance.

Top view: There should be 10-15mm clearance between the bar and grille/bumperettes.

153. Once happy with alignment, tighten all 8x M12 bolts.

TOOLS REQUIRED

- Lifting Trolley
- 18/19mm socket/spanner

FASTENERS



154. Plug in the bumper harness connectors on both LH and RH sides.

You will need to unclip the harnesses from the chassis (including active air dam on LH) to get enough length.

TOOLS REQUIRED

FASTENERS

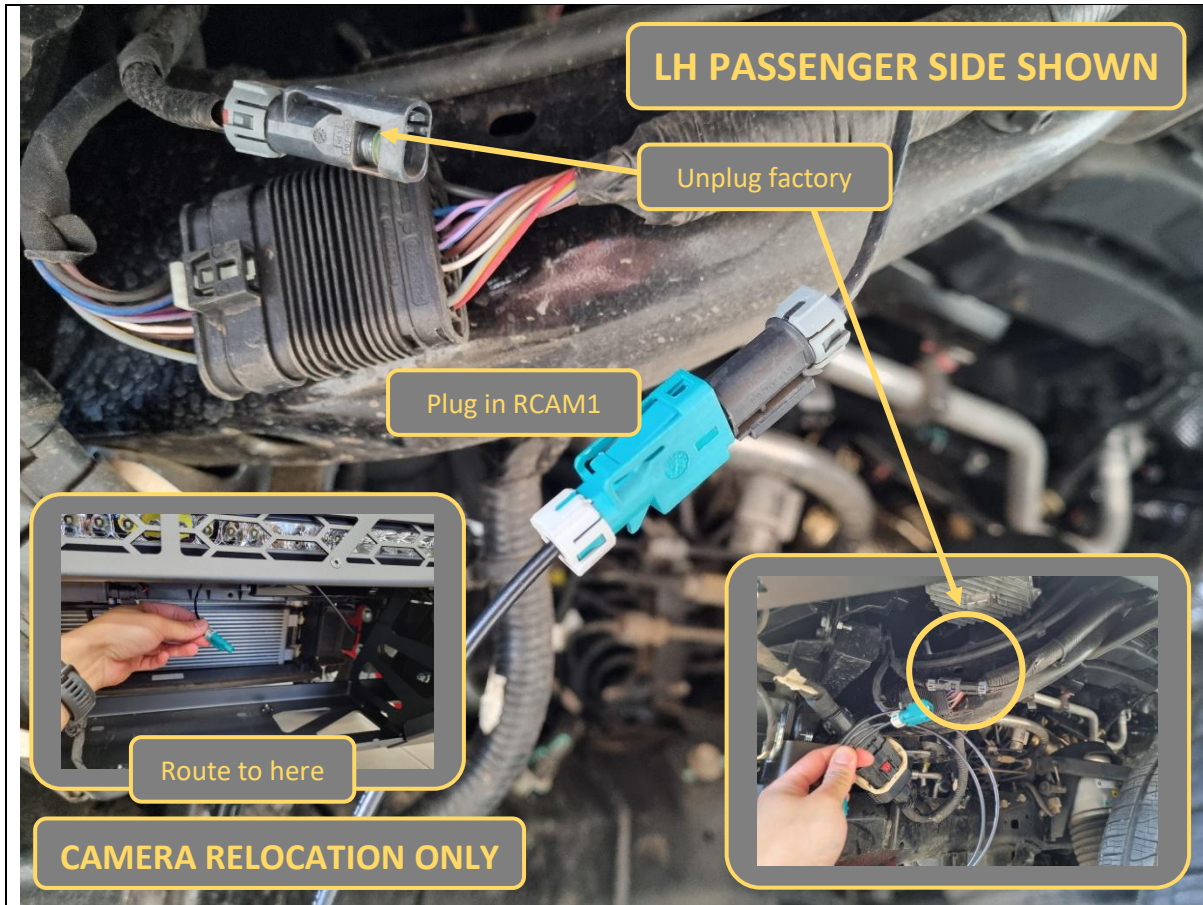

155. If relocating the camera, unplug the coaxial connector under the LH headlight and plug the supplied RCAM1 extension harness in its place.
156. Route the harness behind the bullbar all the way to the central winch cutout area.

TOOLS REQUIRED

FASTENERS



157. If fitting a winch, do so now.

Ensure the radar/camera harnesses do not get squished.

This bar is designed to fit most low mount winches, in foot down configuration. WARN ZEON 12 is the largest physical sized winch confirmed to fit.

Ensure clutch handle will be accessible through opening in front mesh panel. Refer to winch instructions regarding changing clutch handle location.

TOOLS REQUIRED

Refer to instructions supplied by winch

FASTENERS

Supplied with winch



158. Apply the remaining 2x cut tape strips to the top and bottom of the centre radar, in the same way as the side radars.

159. Remove the backing film off the tape strips on the radar, then insert it into the back of the mesh fairlead as shown.

Ensure the radar orientation matches the images exactly, with the plug on the same side as it was in the original bumper.

TOOLS REQUIRED

Utility knife

FASTENERS



- 160. Take the B-0821 radar clamp bracket and fit it on top of the radar.
- 161. Press down firmly to ensure radar is clamped in and can't move around.

TOOLS REQUIRED

FASTENERS

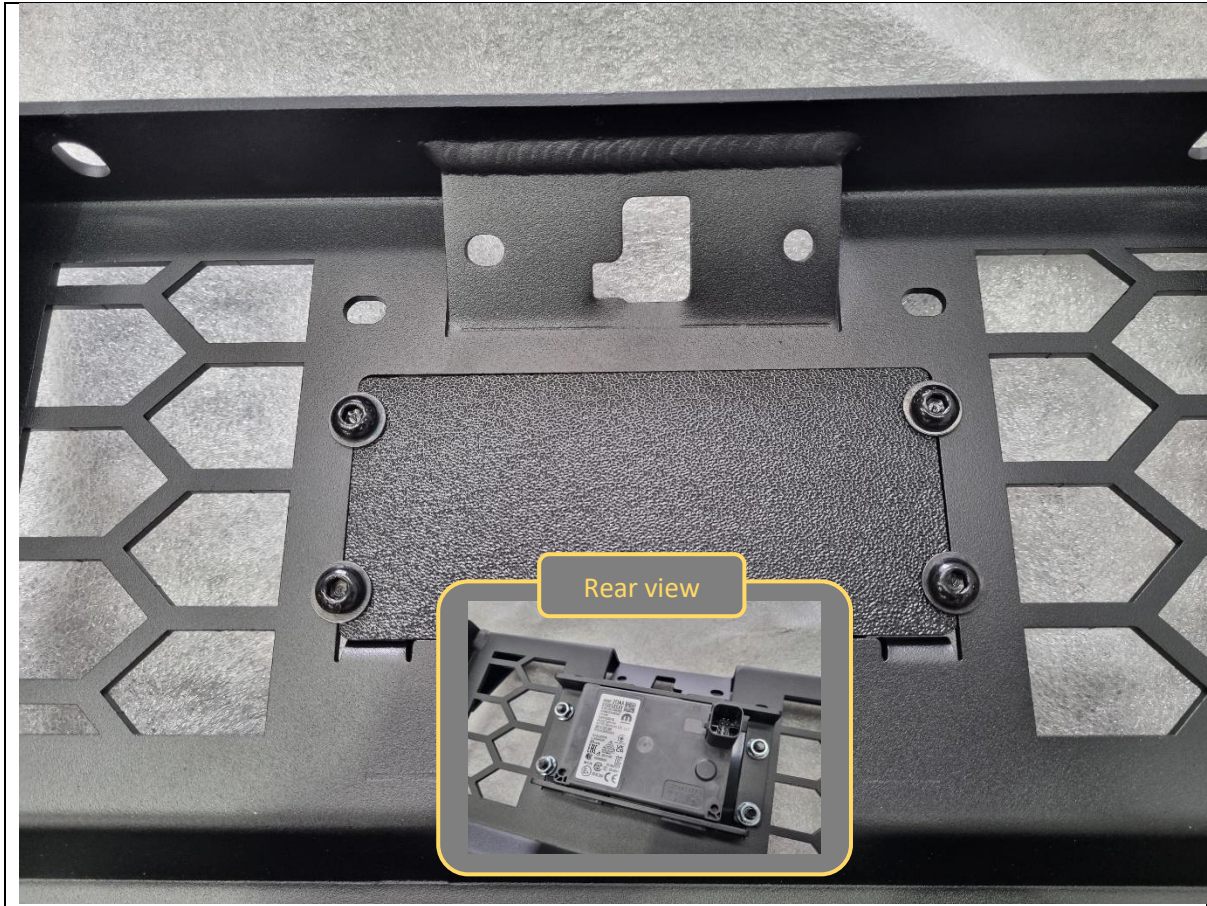

162. Fit the plastic N-0007 radar cover panel (textured face on the outside) to the front of the mesh fairlead.

Secure to the radar clamp bracket on the back with 4x M6x16 black button head bolts, black washers and flange nuts.

TOOLS REQUIRED

4mm hex/Allen key

FASTENERS

4x M6x16 black button head
4x M6 black washer
4x M6 flange nut



CAMERA RELOCATION ONLY

- 163. Unclip and separate the front camera from its original plastic mounting bracket.
 - 164. Position the camera on the front of the mesh and feed the camera cable through the cutout opening.
- Ensure the camera orientation matches the original position in the grille, with labelling facing upwards.

TOOLS REQUIRED

FASTENERS



165. Fit the B-1709 camera clamp bracket on top of the camera, then secure to the mesh fairlead using 2x M6x12 hex bolts, washers and flange nuts.

TOOLS REQUIRED

10mm socket/spanner

FASTENERS

2x M6x12 hex bolt
2x M6 flat washer
2x M6 flange nut

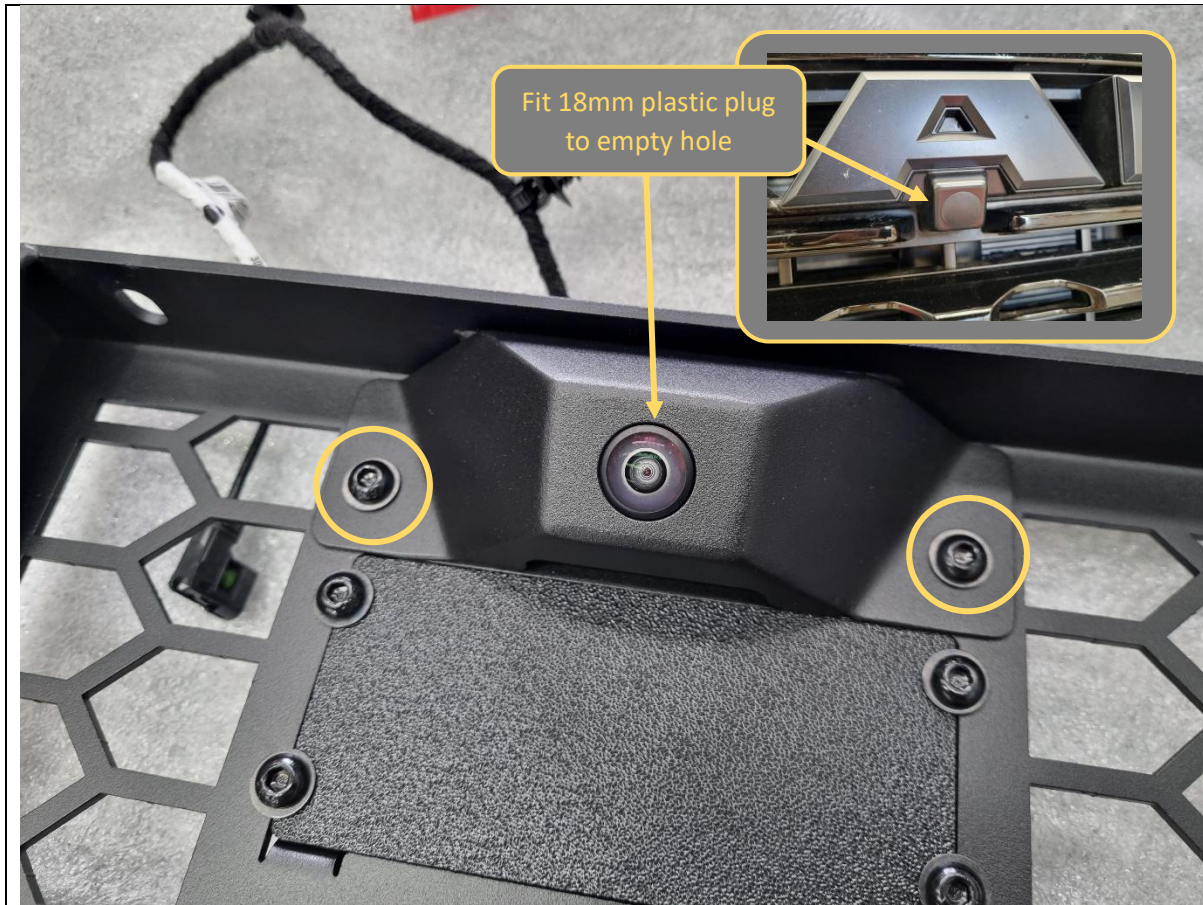

166. Fit the B-1710 camera housing to the front of the mesh fairlead, over the camera.

Secure using 2x M6x16 black button head bolts, black washers and flange nuts.

Do this even if not relocating camera.

167. Fit the supplied 18mm plastic plug to either the camera hole leftover in the grille, or in the housing on the mesh fairlead.

TOOLS REQUIRED

4mm hex/Allen key

FASTENERS

2x M6x16 black button head
2x M6 black washer
2x M6 flange nut

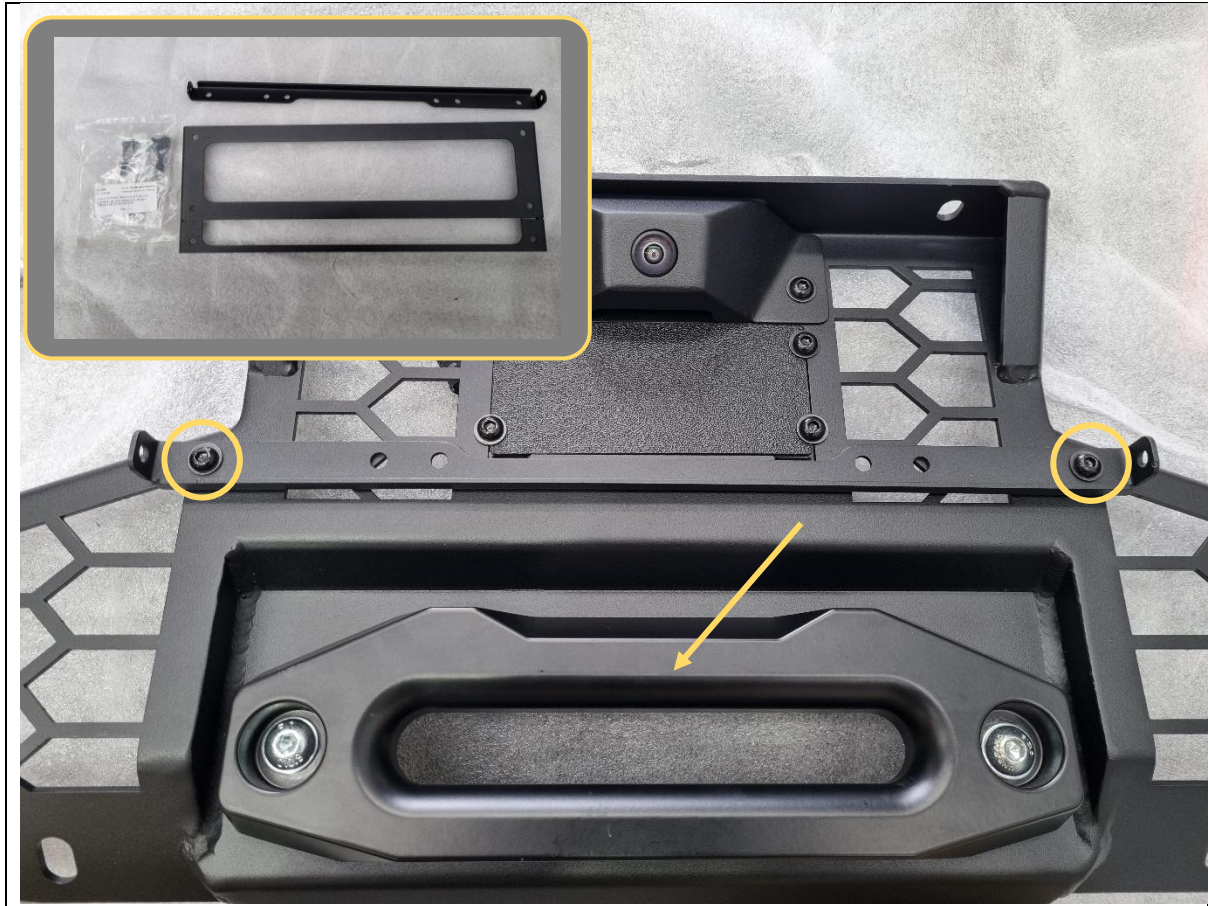

168. If fitting a winch, fit the hawse fairlead to the centre mesh now using M10 or 3/8" fasteners supplied with the winch. This bar is only compatible with hawse type fairleads.

169. Locate the number plate flip brackets and fastener kit.

Fit the base bracket to the centre mesh and secure with 2x M6x16 black button head bolts, black washers and flange nuts.

TOOLS REQUIRED

Refer to instructions supplied by winch

4mm hex/Allen key

FASTENERS

Supplied with winch

2x M6x16 black button head

2x M6 black flat washer

2x M6 flange nut

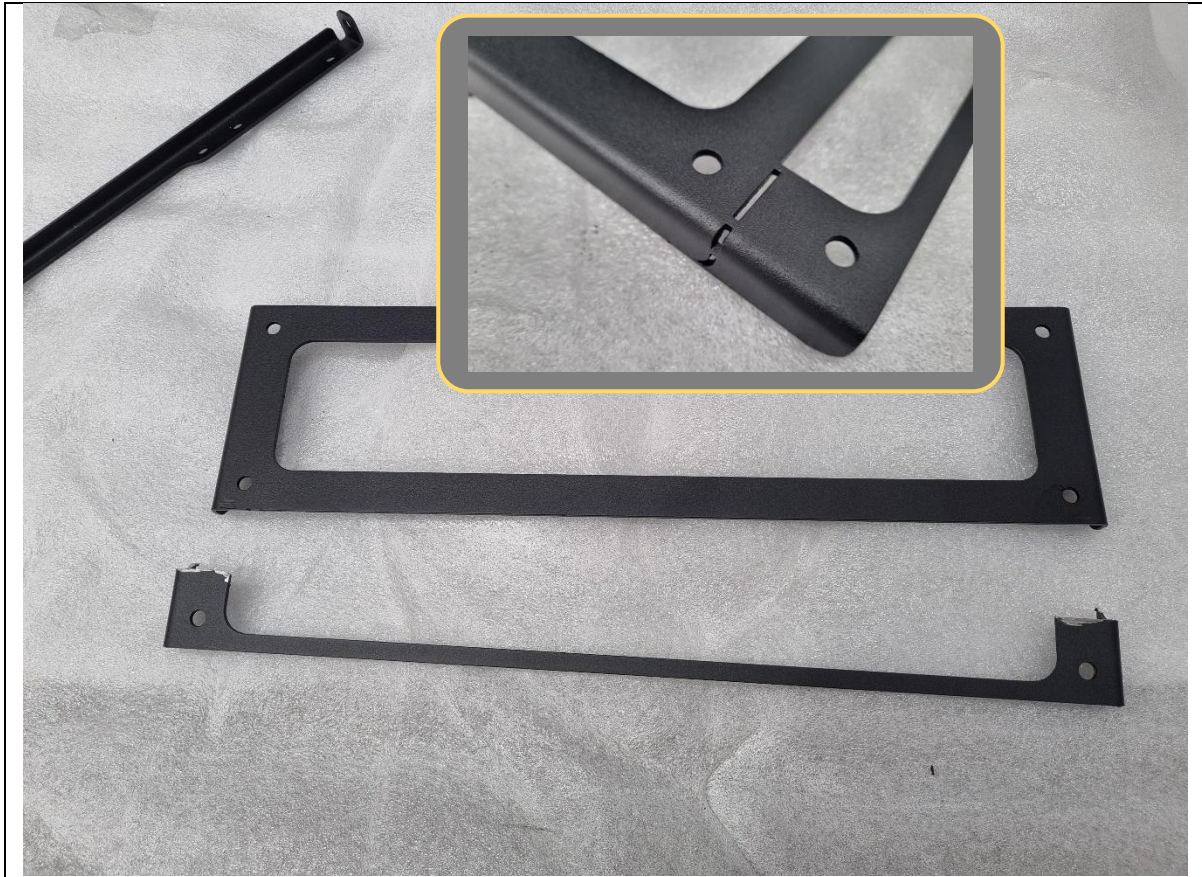

<p>The number plate flip bracket is designed to be compatible with both standard and slimline number plates.</p> <p>170. If fitting to a slimline plate, use an angle grinder to cut the bottom section of the bracket off along the laser cut grooves.</p> <p>171. Deburr the cut edges, then paint over to prevent rust.</p>	<p>TOOLS REQUIRED</p> <p>Angle grinder</p> <p>Deburring tool</p> <p>Black spray paint</p>
	<p>FASTENERS</p>

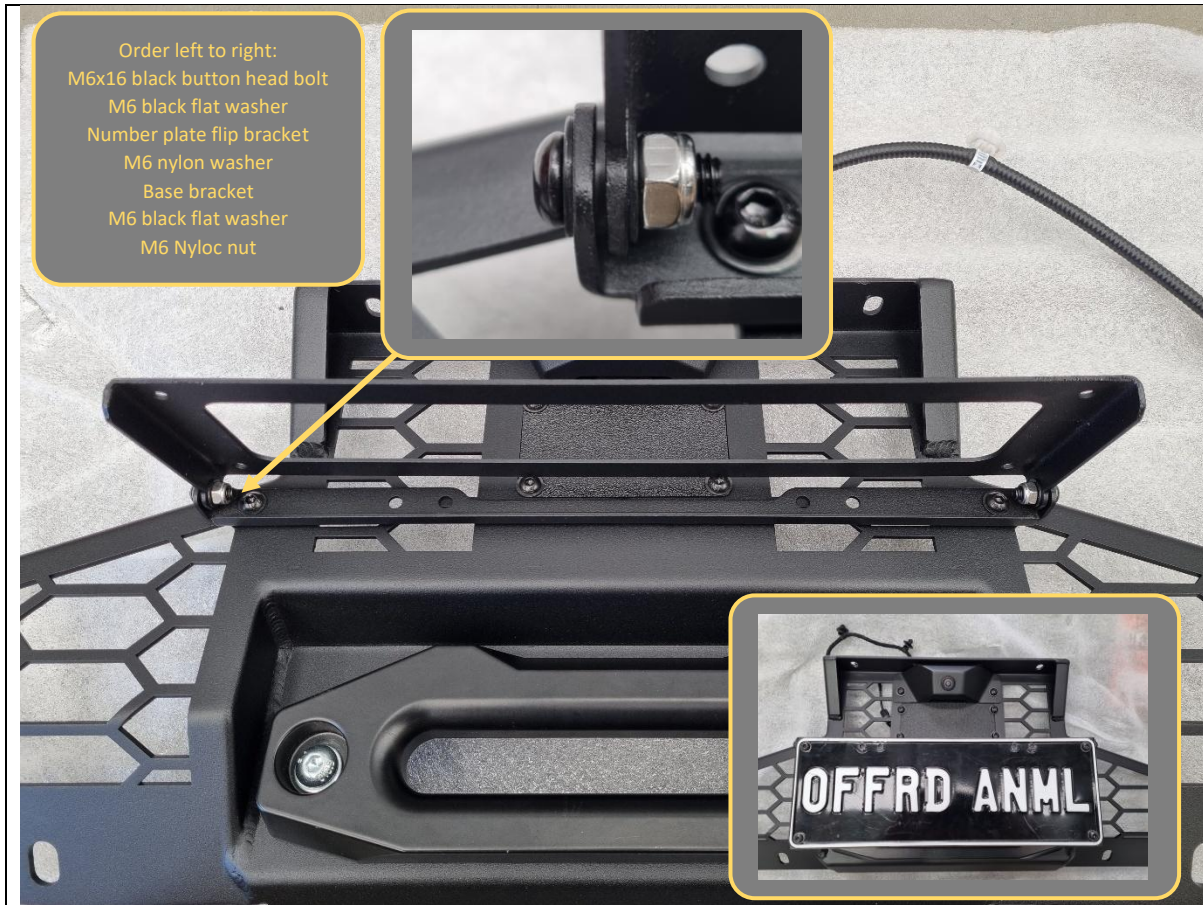

- 172. Fit number plate flip bracket to base bracket as shown above. Tighten bolts so that flip bracket can be moved by hand with some friction resistance.
- 173. Attach number plate to flip bracket using 4x M6x12 black button head bolts, black washers and flange nuts.

TOOLS REQUIRED

- 4mm hex/Allen key
- 10mm spanner

FASTENERS

- 4x M6x12 black button head bolt
- 2x M6x16 black button head bolt
- 8x M6 black flat washer
- 4x M6 flange nut
- 2x M6 nylon washer
- 2x M6 Nyloc nut

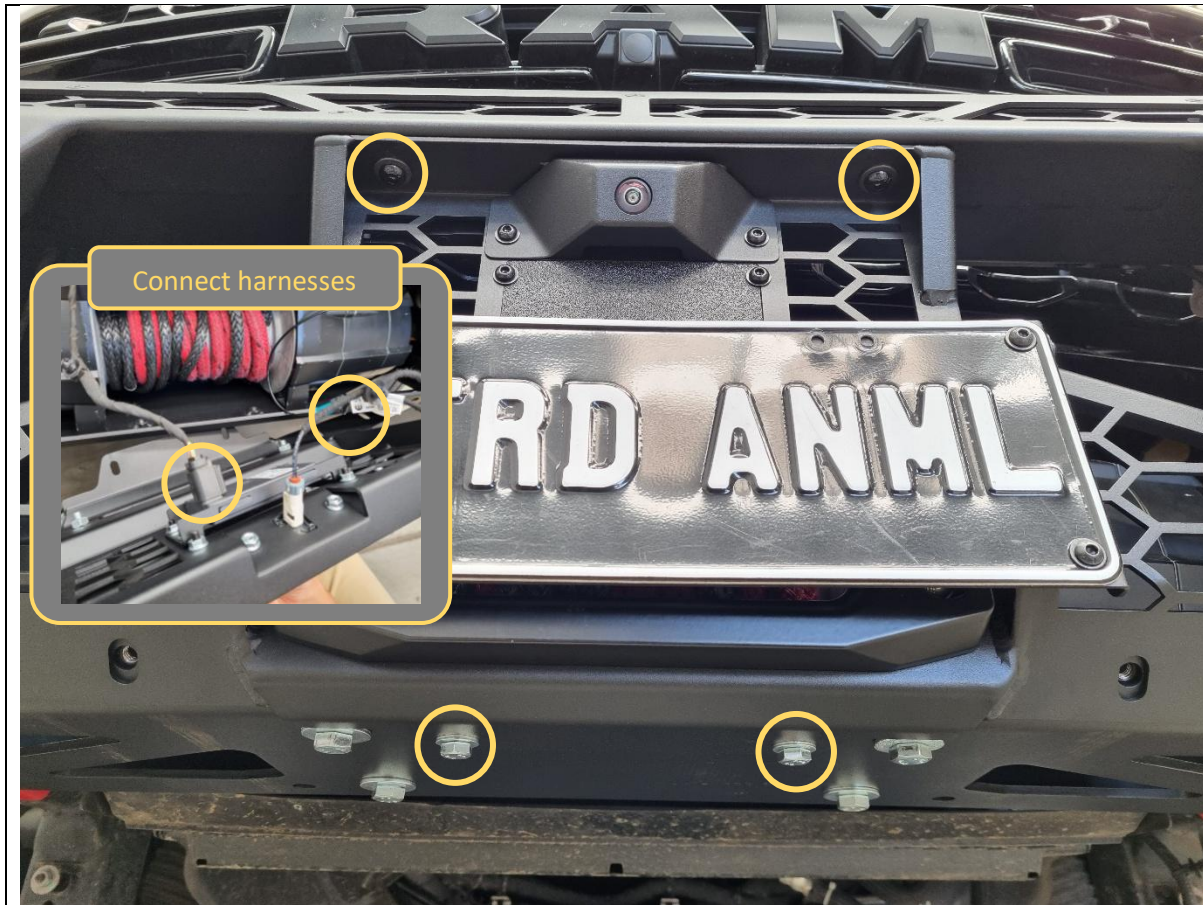

- 174. Present the centre mesh up to the centre opening of the bar. If a winch is fitted, feed the winch rope through the hawse fairlead and fit the winch hook.
- 175. Connect the radar and camera (if being relocated) back to the harnesses on the vehicle side.
- 176. Secure the centre mesh to the bar using 2x M8x16 black button head bolts + black washers (top), 2x M8x20 hex head bolts + flat washers (bottom).

TOOLS REQUIRED

- 13mm socket/spanner
- 5mm hex/Allen key

FASTENERS

- 2x M8x16 black button head
- 2x M8 black washer

- 2x M8x20 hex head
- 2x M8 flat washer



177. **Toro only.** Due to the CAN Bus headlight system, the indicator signal for the repeater lamps in the bullbar can only be obtained via the side repeater lamps in the front doors. 2x piggyback harnesses (left and right) are supplied for this.

178. **Toro only.** Open the front door and remove 2x plastic access panels with a trim tool or flat blade screwdriver. Take care not to scratch the plastic.

179. **Toro only.** Remove the 3x 10mm hex bolts that were hidden underneath.

TOOLS REQUIRED

10mm socket

FASTENERS

3x factory 10mm hex bolt

Per side

Retain

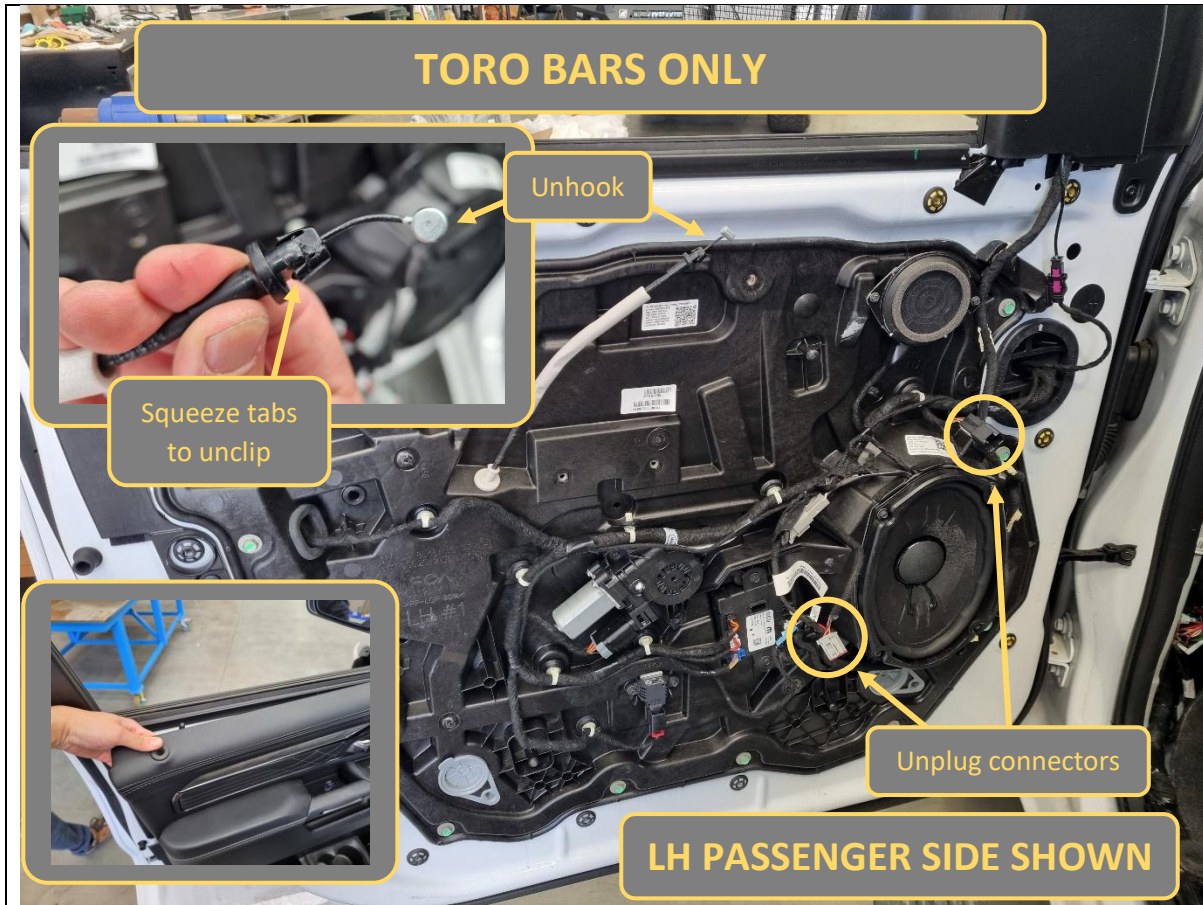

- 180. **Toro only.** Grab the door card from the top edge and gently pull outwards to start releasing clips.
- 181. **Toro only.** Reach in behind the door card and unplug 2x electrical connectors.
- 182. **Toro only.** Unhook the end of the door handle cable, and squeeze tabs on retaining clip to release cable from door card.
- 183. **Toro only.** Door card is now free to be fully removed and set aside.

TOOLS REQUIRED

FASTENERS

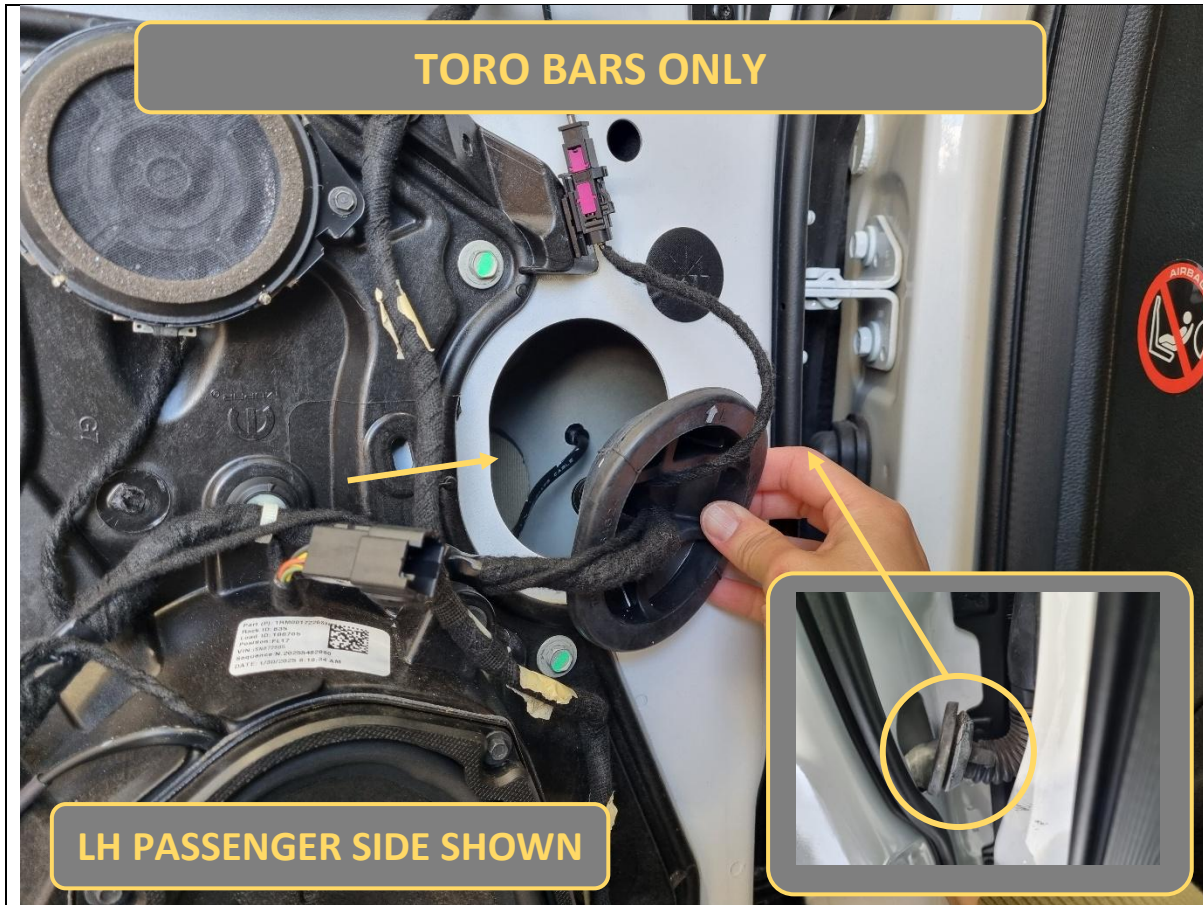

- 184. **Toro only.** Remove the large rubber grommet in the door.
- 185. **Toro only.** Remove the rubber grommet on the door-to-body connector boot (see inset photo).

TOOLS REQUIRED

FASTENERS

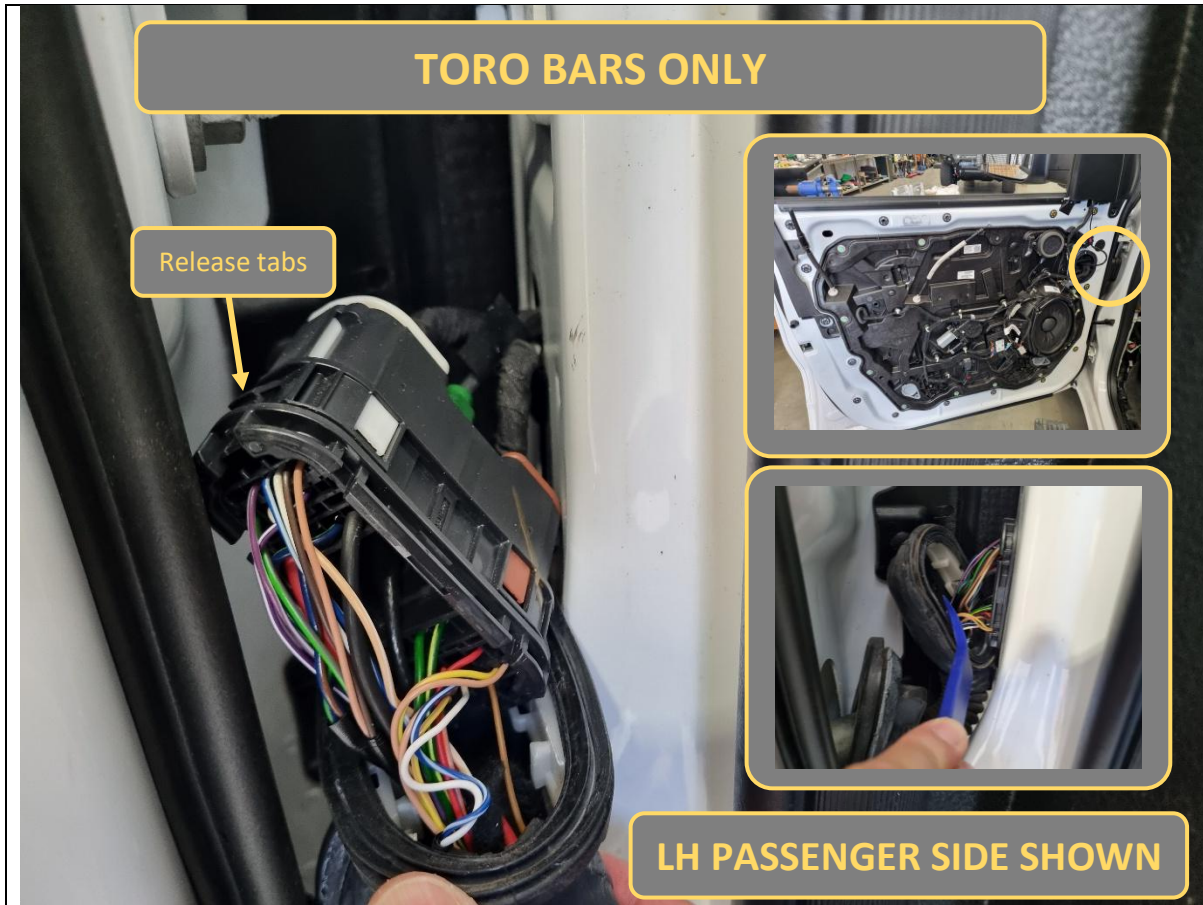

- 186. **Toro only.** Use a plastic trim tool to pry off the rubber boot over the main door harness connector.
- 187. **Toro only.** Use a right angle pick (or flat blade screwdriver) and release the tabs holding the main door harness connector to the vehicle cabin.

TOOLS REQUIRED

- Plastic trim tool
- Right angle pick

FASTENERS



- 188. **Toro only.** On the driver RH side, pull outwards to unclip the plastic cover panel for the scissor jack.
- 189. **Toro only.** On both sides, pull upwards to unclip the door sill scuff panel.

TOOLS REQUIRED

FASTENERS



190. **Toro only.** In the LH passenger side footwell, remove 3x plastic scrivets and 1x plastic push clip holding the lower glove box cover panel.

Retain the clips.

TOOLS REQUIRED

Phillips head screwdriver

Trim tool
or
Flat blade screwdriver

FASTENERS

Retain

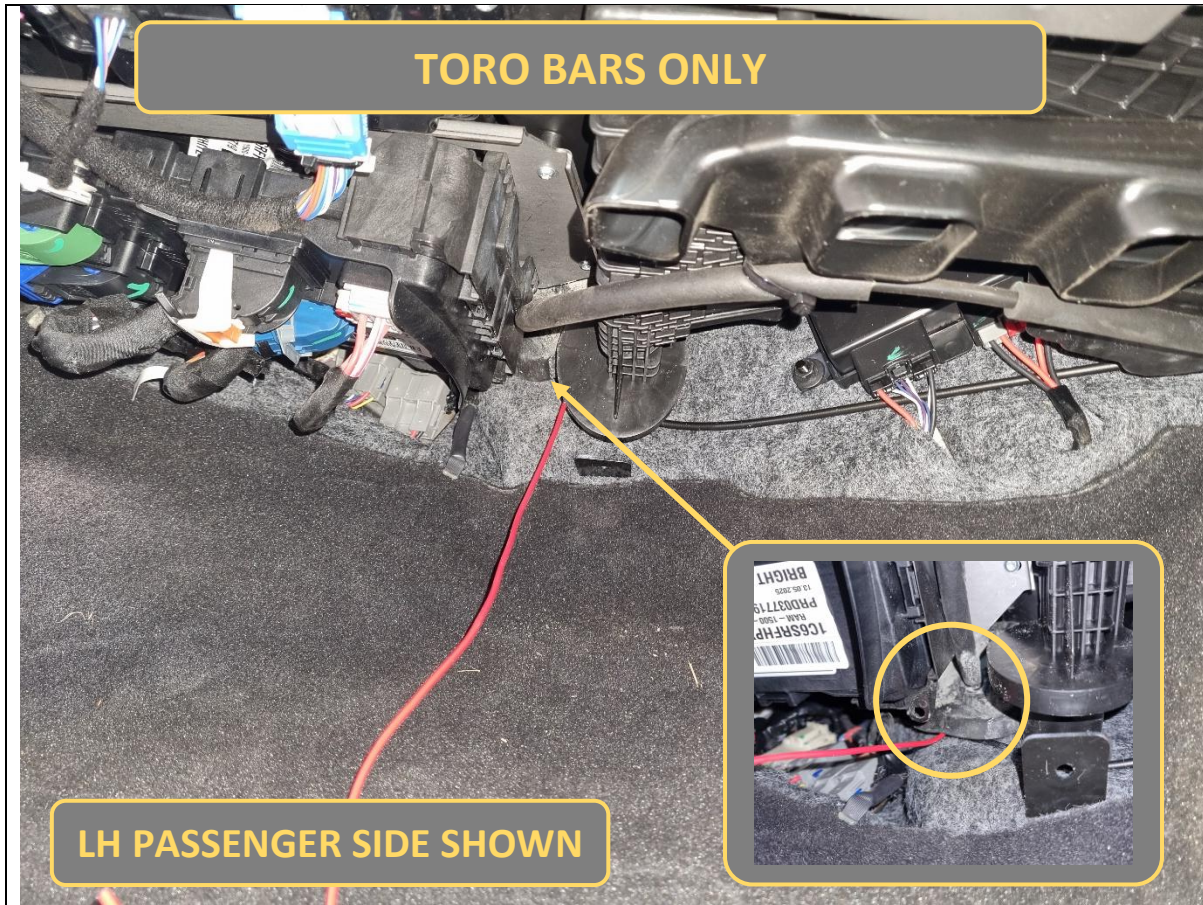

191. **Toro only.** At the very back of the LH passenger footwell is a pass-through grommet to the other side of the engine bay firewall.

This is the suggested location for routing the indicator piggyback harness to the front of the vehicle. More on this later.

TOOLS REQUIRED

FASTENERS



192. **Toro only.** Inside the door, locate the harness labelled 'DT22 Side Repeater Patch Harness' with a Walkinshaw (WAG) part number.
193. **Toro only.** Remove the loom tape to expose a Deutsch 2-pin connector. Unplug it and plug in the supplied Offroad Animal indicator piggyback harness into the factory patch harness.

This needs to be done on both sides of the car to get LH and RH indicator signals.

Note: If one harness is longer than the other, use that on the RH side.

Note: If you are supplied with a piggyback harness labelled ALO-W6, you will need to cut off one of the male Deutsch connectors on the piggyback and add in your own wire extension.

We recommend 2 metres of automotive grade twin core sheathed cable for the LH side, and 5 metres for the RH.

TOOLS REQUIRED

FASTENERS

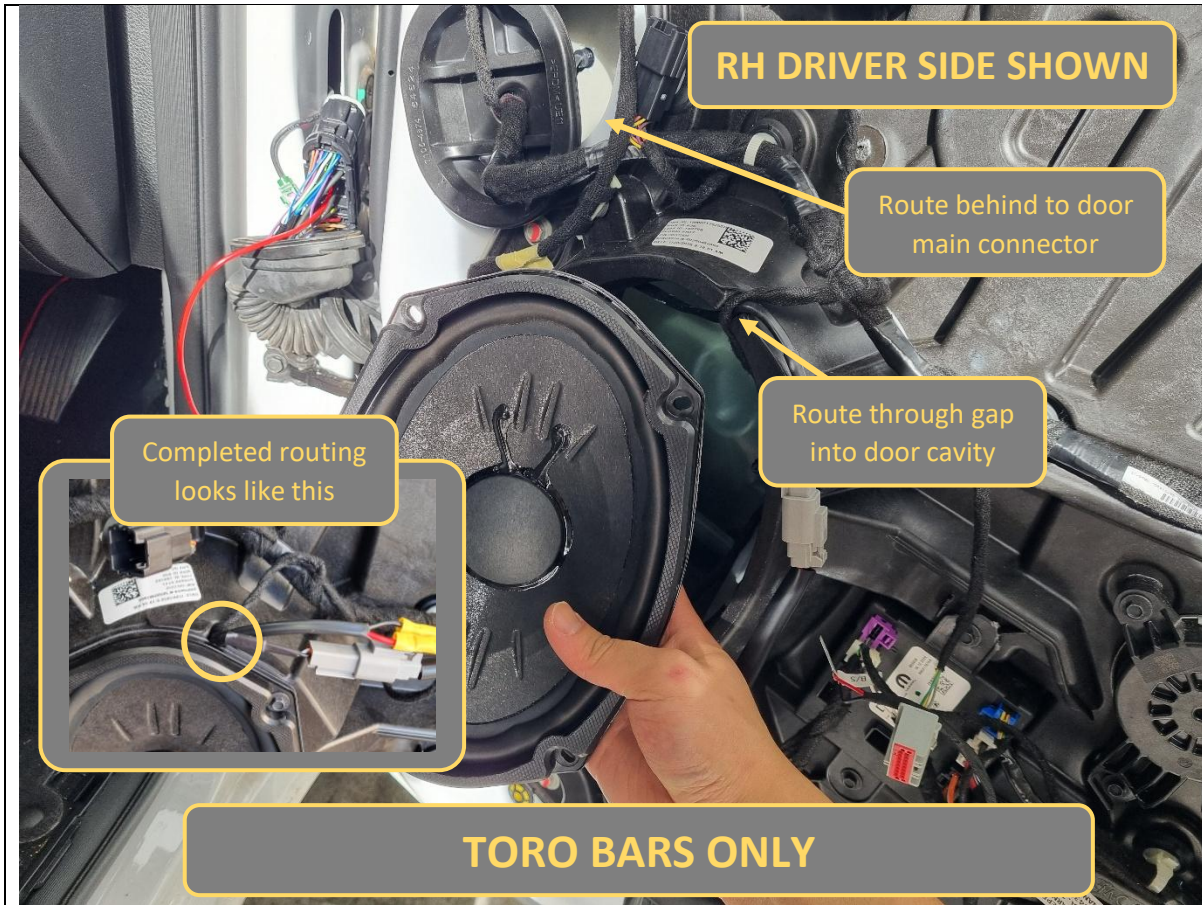

<p>The following is the suggested cable routing path.</p> <p>194. Toro only. Remove 4x 6mm hex screws holding the door speaker. Retain the screws.</p> <p>195. Toro only. Route the piggyback harness through the slot behind the speaker and into the door cavity. This should also be where the factory side repeater patch harness is routed.</p>	<p>TOOLS REQUIRED</p> <p>6mm socket/spanner</p>
<p>196. Toro only. Route the harness through the inside of the door cavity to the main connector to the vehicle cabin.</p>	<p>FASTENERS</p> <p>Retain</p>



RH DRIVER SIDE SHOWN

- 197. **Toro only.** Next route the piggyback harness through the rubber boot between door and cab.
- 198. **Toro only.** Then feed the harness through the large gap in the middle of the connector plug itself and into the vehicle cab.

TOOLS REQUIRED

FASTENERS

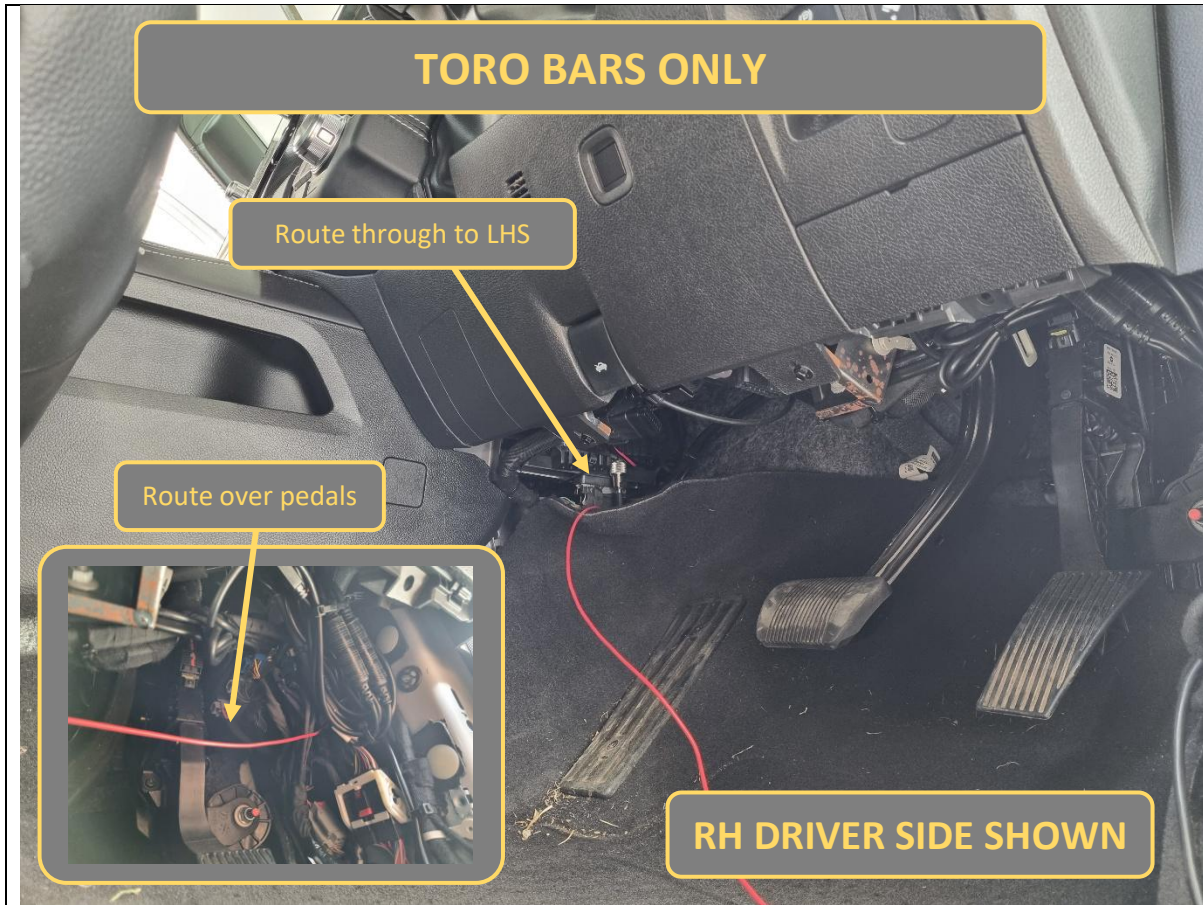

199. **Toro only.** The firewall pass-through on the driver side isn't easily accessible.

Therefore, we suggest routing the harness over the pedals and behind the centre console to the LH side.

TOOLS REQUIRED

FASTENERS

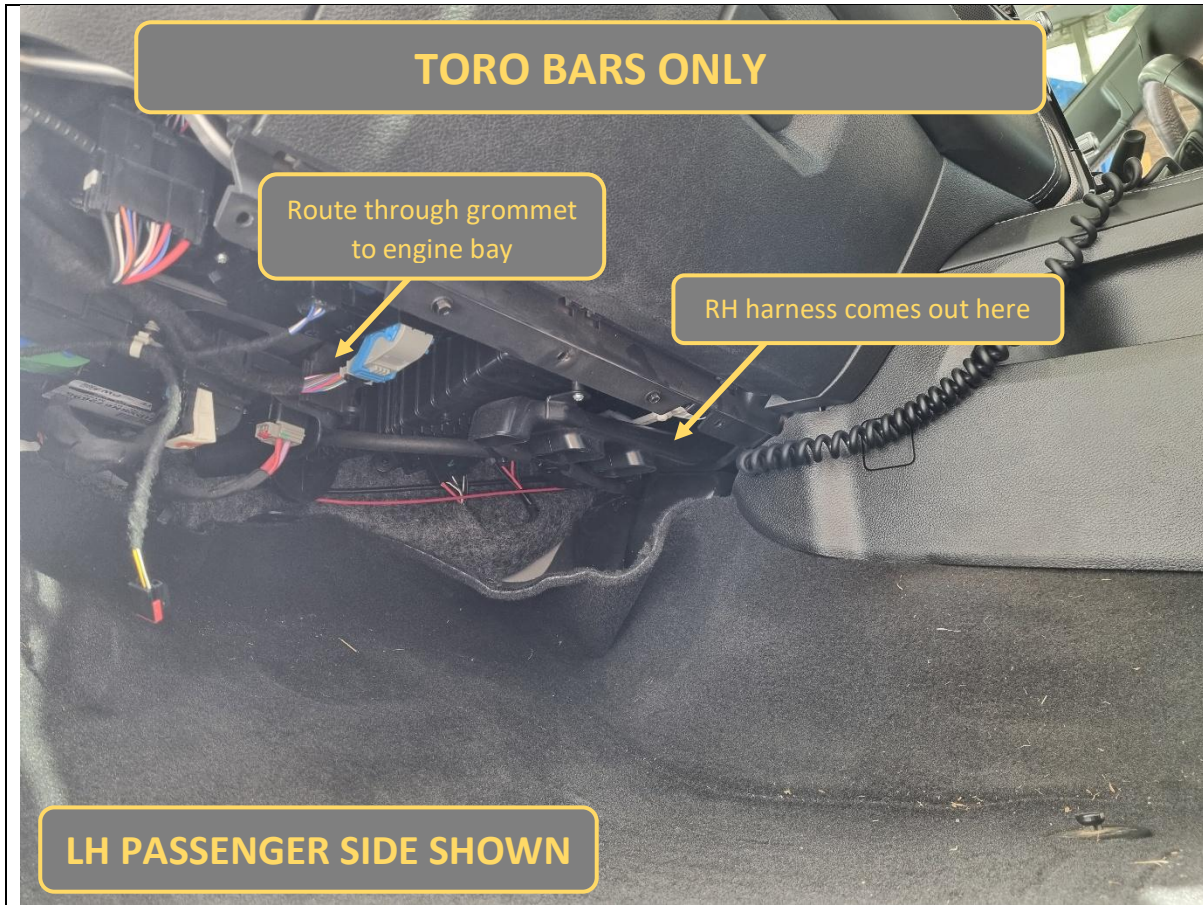

<p>200. Toro only. Both LH and RH piggyback harnesses should now be in the LH passenger footwell.</p> <p>201. Toro only. Now feed both harnesses through the firewall grommet shown earlier, into the engine bay.</p> <p>202. Toro only. Route the harnesses on top of the LH chassis rail to the front of the car. The RH harness needs to cross back over to the RH indicator repeater in the bull bar.</p>	<p>TOOLS REQUIRED</p> <p>Cable ties</p>
<p>203. Toro only. Ensure the wiring will not chafe or get in contact with anything hot in the engine bay. Also ensure the wiring will not get snagged/caught on the pedals in the driver footwell. Cable tie secure the piggyback harness at multiple locations.</p> <p>204. Toro only. Re-fit all the trim panels and door card components in reverse order.</p>	<p>FASTENERS</p>



- 205. **Toro only.** Connect the indicator repeater lamps to the piggyback harnesses (solder/crimp together, ensure well insulated). Refer to packaging on indicator lamps for pinout.
- 206. Turn the car on and confirm function of all tech (indicator lights, fog lights, camera, radar and parking sensors).

TOOLS REQUIRED

- Soldering Iron
- Solder
- Wire Strippers
- Heat Shrink
- Electrical Tape

FASTENERS



- 207. Fit the bash plate mount to the chassis where the active air dam assembly was bolted to.
- 208. Secure at the front by re-using the factory 13mm flange nuts from the air dam assembly.
- 209. Secure at the rear with 1x M12x30 hex bolt, flat washer and mini M12 nutplate (30mm stem).

TOOLS REQUIRED

13mm socket/spanner
18/19mm socket/spanner

FASTENERS

4x factory 13mm flange nut
Retained

2x M12x30 hex bolt
2x M12 flat washer
2x mini M12 nutplate



- 210. Fit the winch strap to the underside of the bullbar. Secure to the weld nuts on the bottom of the winch cradle with 2x M10x30 hex bolts and washers.
- 211. Secure to the bash plate mounts at the rear with 2x M10x30 hex bolts, washers and flange nuts.

TOOLS REQUIRED

16/17mm socket/spanner

FASTENERS

4x M10x30 hex bolt
4x M10 flat washer
2x M10 flange nut

OPTIONAL ACTIVE AIR DAM MOTOR RELOCATION



212. As mentioned earlier, the active air dam motor can be left off the vehicle and will not leave warning lights on the dash, but may leave behind a code on the ECU.

If you want to keep it plugged in the vehicle, follow the procedure outlined in the next few pages.

213. Remove 2x 10mm hex bolts holding the air dam spoiler to the actuator arm on the motor side.

TOOLS REQUIRED

10mm socket/spanner

FASTENERS

2x 10mm hex bolt

Discard

OPTIONAL ACTIVE AIR DAM MOTOR RELOCATION

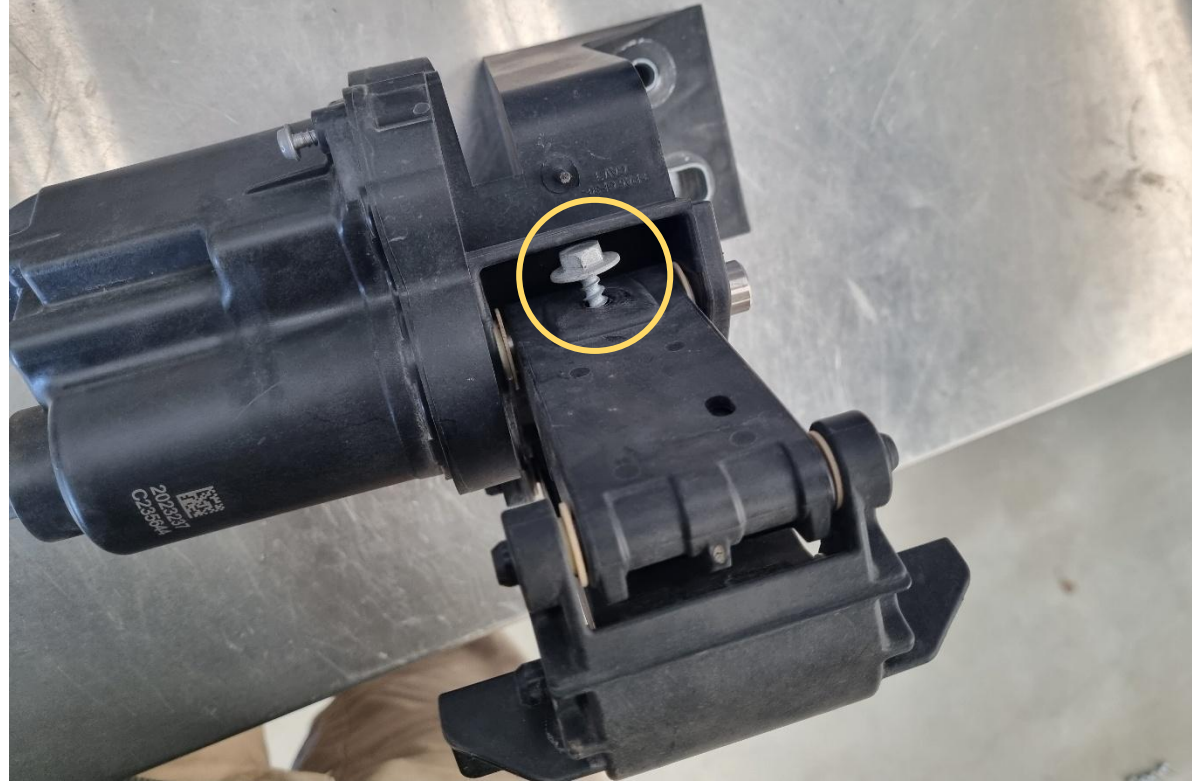

214. Remove 1x 10mm hex bolt and the plastic threaded block underneath that clamps onto the drive shaft.

TOOLS REQUIRED

10mm spanner

FASTENERS

1x 10mm hex bolt

Discard

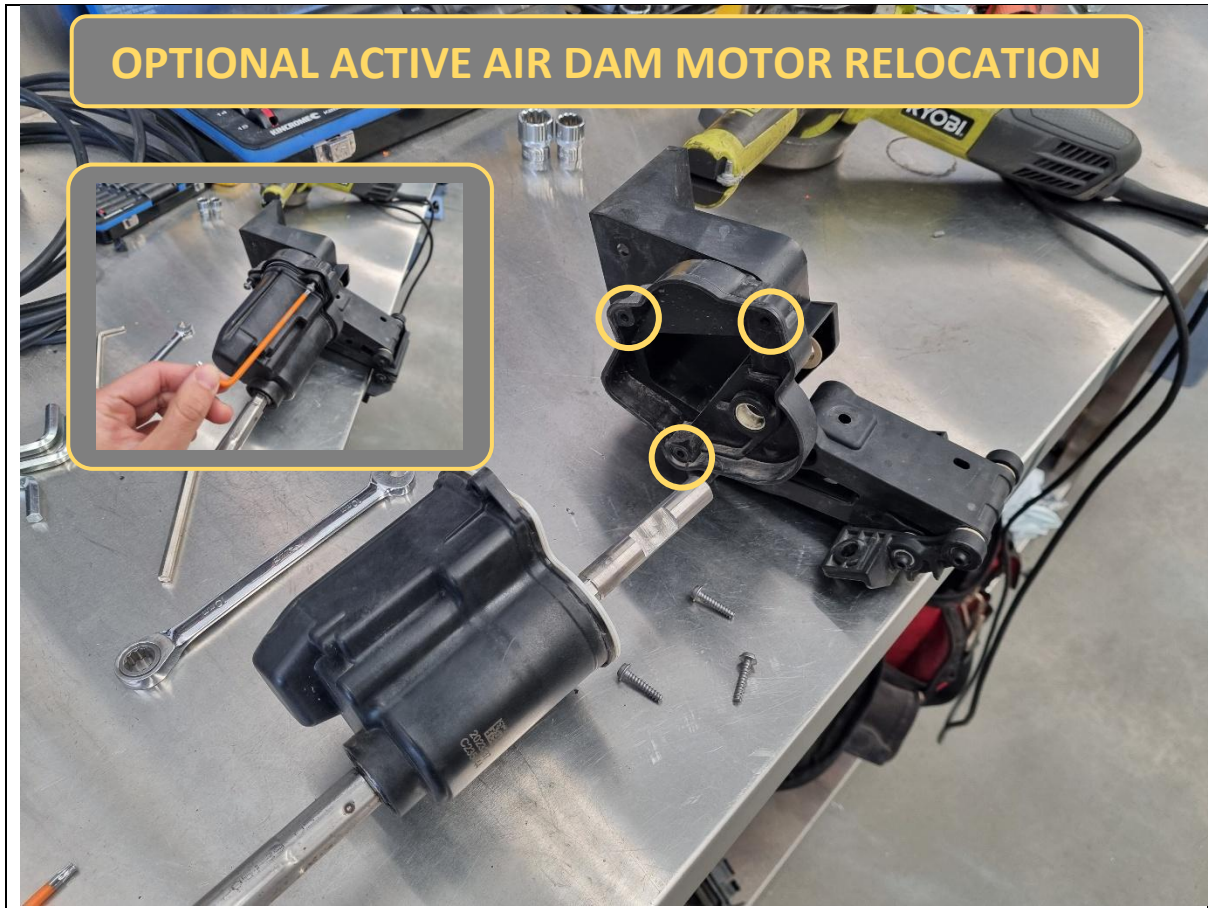

215. Remove 3x T20 Torx screws holding the actuator arm to the main motor.

TOOLS REQUIRED

T20 Torx bit

FASTENERS

3x T20 Torx screw

Discard

OPTIONAL ACTIVE AIR DAM MOTOR RELOCATION

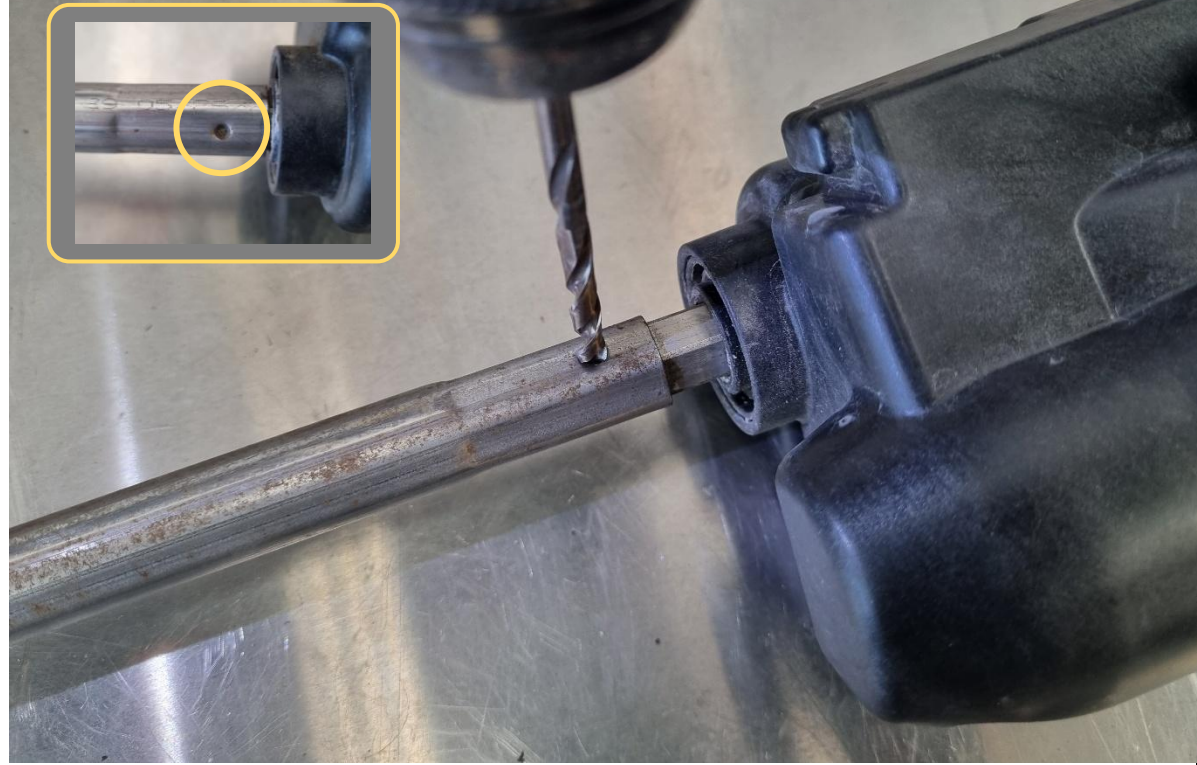

216. There are some dimples holding the drive shafts together. Drill these out with a 4.5mm drill bit.

TOOLS REQUIRED

Electric drill
4.5mm drill bit

FASTENERS

OPTIONAL ACTIVE AIR DAM MOTOR RELOCATION



217. Remove all the drive shafts from the motor.

TOOLS REQUIRED

FASTENERS

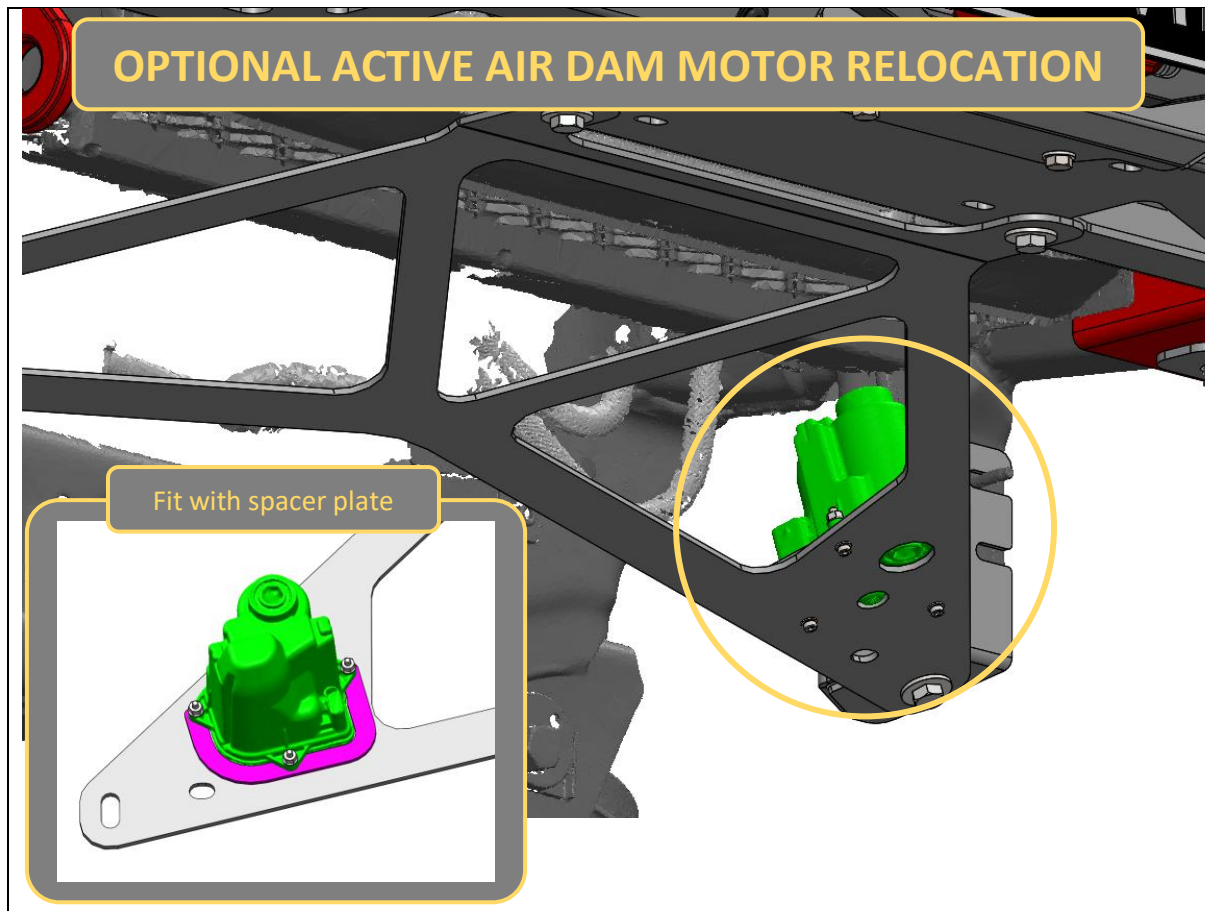

- 218. Fit the motor with P-0512 spacer plate onto the winch strap on the LH passenger side as shown.
- 219. Secure with 3x M4x25 socket head cap screws, washers and flange nuts.
- 220. Plug the air dam electrical harness back into the motor.

TOOLS REQUIRED

3mm hex/Allen key

FASTENERS

3x M4x25 cap screw
3x M4 flat washer
3x M4 flange nut



221. Fit 2x M8 cage nuts to the inside of the main bash plate, as shown.

Use a flat blade screwdriver to assist.

222. Also affix the ADR compliance label to the inside face of the bash plate.

TOOLS REQUIRED

Flat blade screwdriver

FASTENERS

2x M8 cage nut

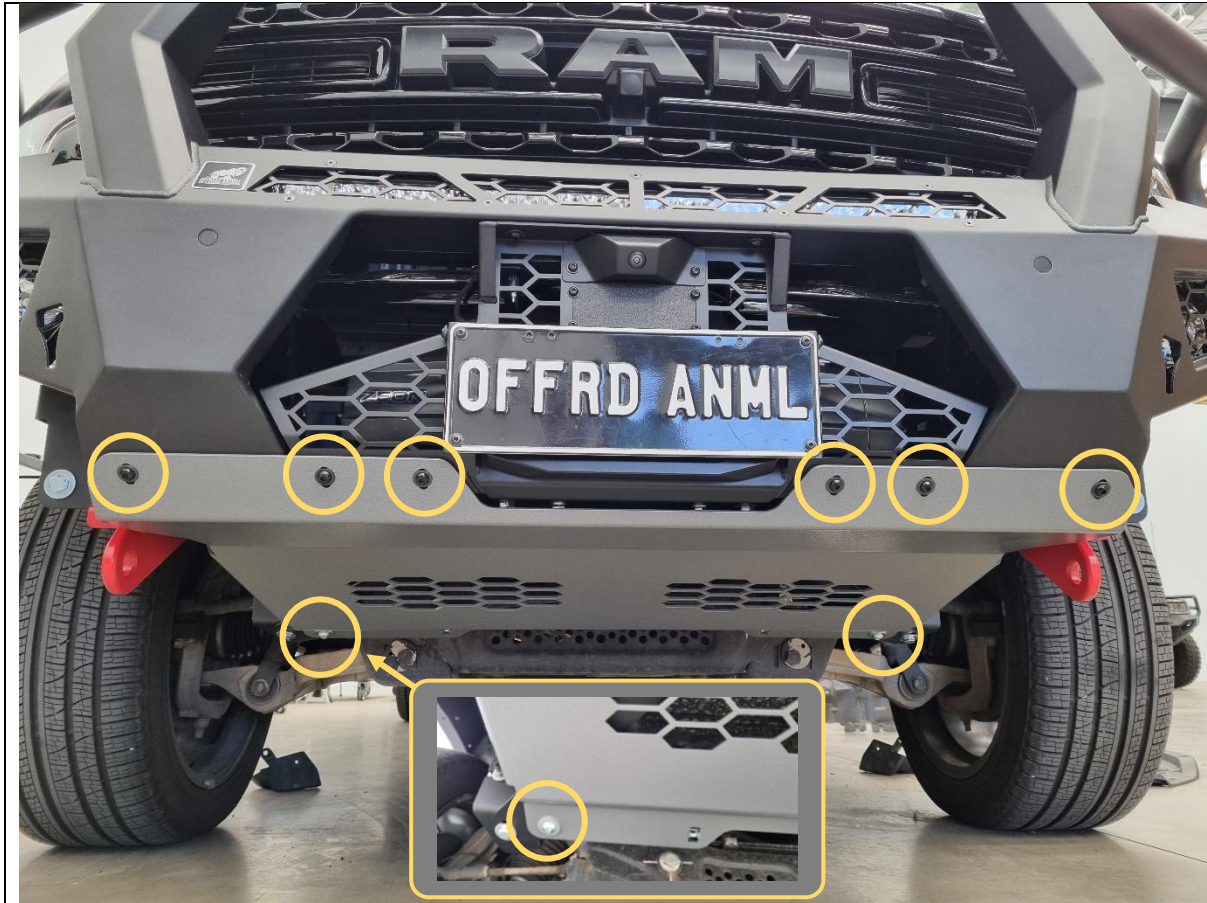

223. Fit the main bash plate to the underside of the vehicle.

Secure to the nutserts in the front to the bull bar with 6x M8x30 black button head bolts and black washers.

Secure the back to the winch strap with 2x M10x30 button head bolts, washers and flange nuts.

TOOLS REQUIRED

5mm hex/Allen key
6mm hex/Allen key

FASTENERS

6x M8x30 black button head
6x M8 black washer

2x M10x30 button head
2x M10 washer
2x M10 flange nut

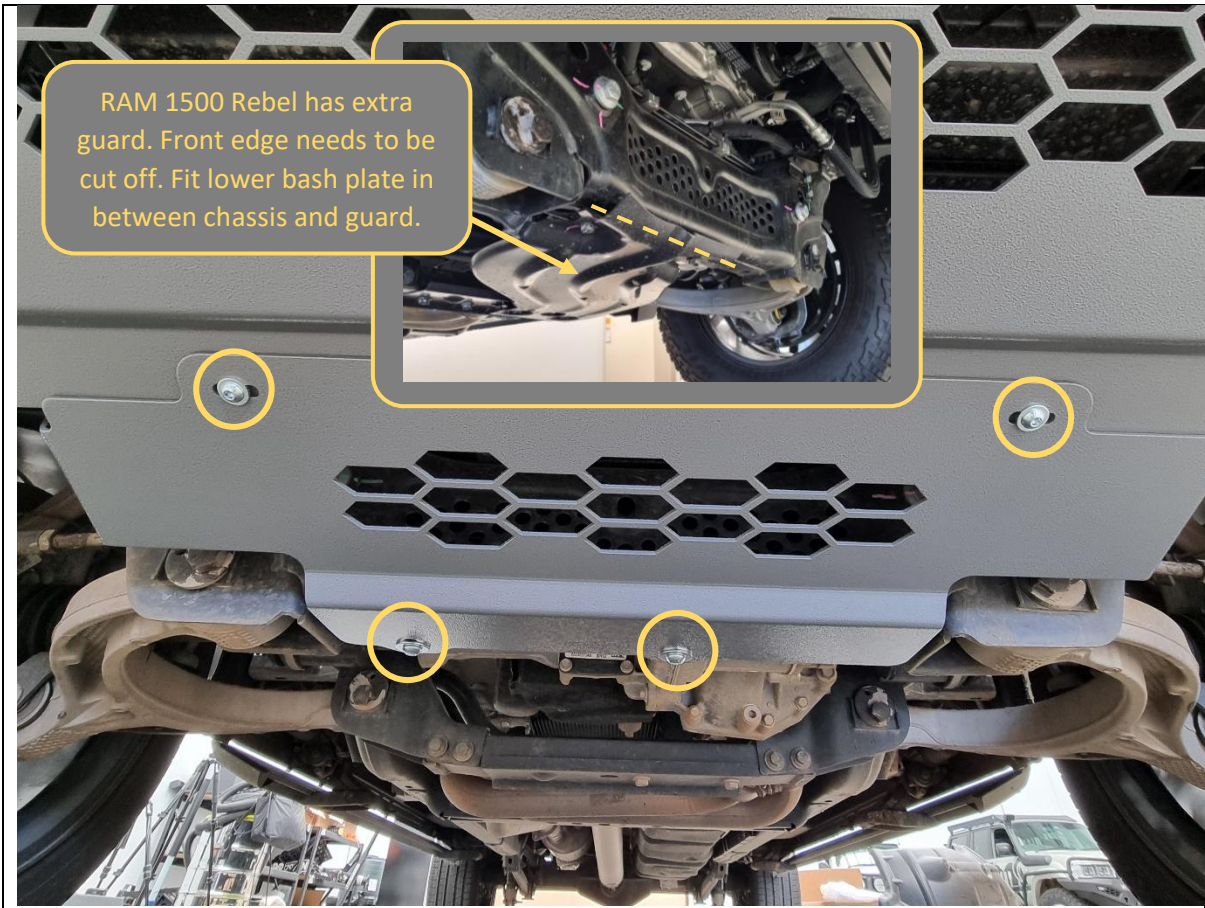

224. Fit the lower bash plate to the underside of the vehicle.

Secure at the front to the cage nuts in the main bash plate with 2x M8x20 button head bolts and washers.

Secure at the rear to the nutserts in the chassis with 2x M10x30 button head bolts at washers.

225. On RAM 1500 Rebel and possible some other models, there is a factory steel guard panel installed.

You will need to trim/angle grind the front edge off to get clearance to fit the lower bash plate. Deburr and paint the cut edges to prevent rust.

Then remove the front bolts and insert the lower bash plate in between the chassis and factory guard.

TOOLS REQUIRED

5mm hex/Allen key
6mm hex/Allen key

(Angle grinder)
(Paint)

FASTENERS

2x M8x20 button head
2x M8 washer

2x M10x30 button head
2x M10 washer

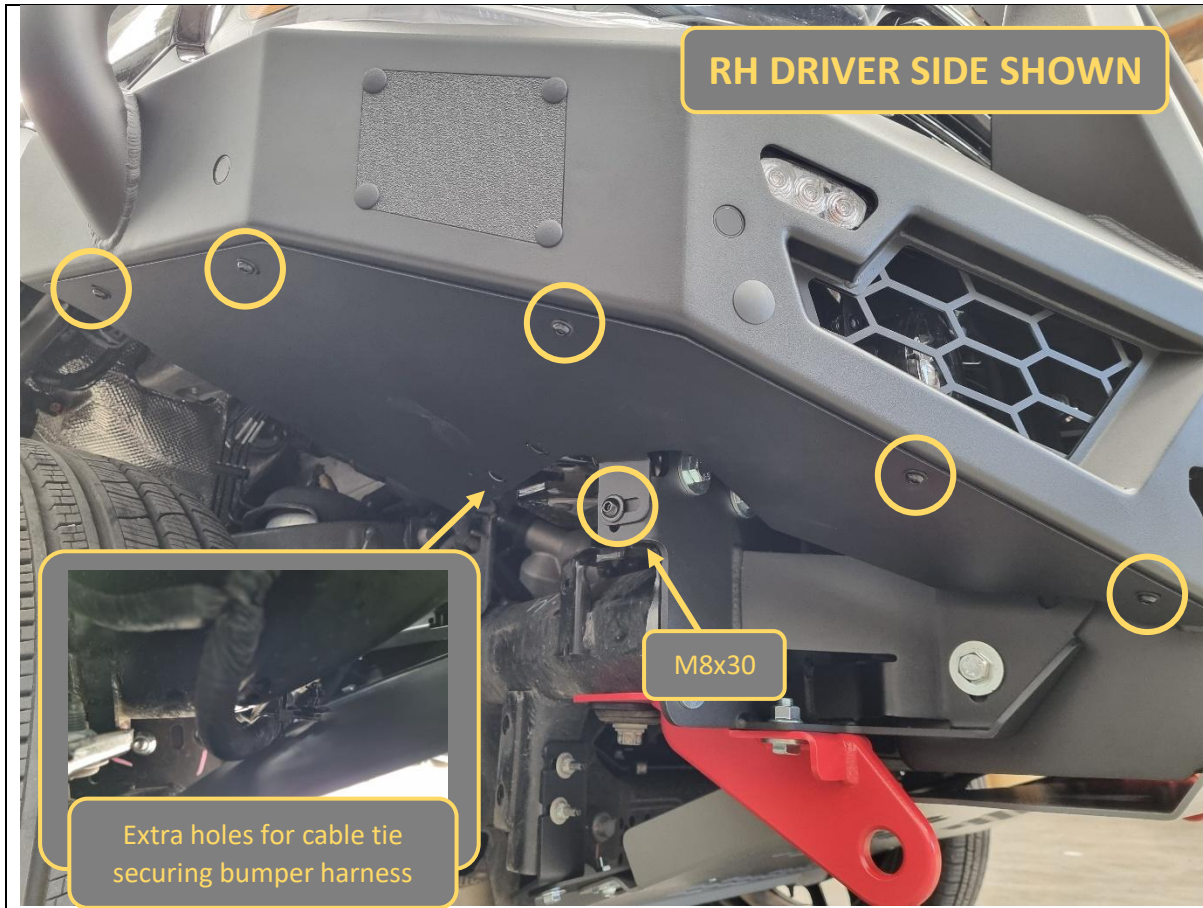

<p>226. Fit the side underpanels to the underside of the bull bar wings.</p> <p>227. Secure each side underpanel to the underside of the bull bar with 5x M6x16 black button head bolts and black washers.</p> <p>228. Secure each side underpanel to the impact assembly with 1x M8x30 black button head bolt, black washer and flange nut.</p> <p>229. Cable tie secure the bumper wiring harness to the 2x extra holes on the side underpanel (see inset photo). Ensure the harness will not rub/chafe on any sharp edges on the bodywork.</p>	<p>TOOLS REQUIRED</p> <p>4mm hex/Allen key 5mm hex/Allen key</p> <p>Cable ties Side cutters</p>
	<p>FASTENERS</p> <p>10x M6x16 black button head 10x M6 black washer</p> <p>2x M8x30 black button head 2x M8 black washer 2x M8 flange nut</p>



230. Trim off the highlighted area on the front outer corner of the wheel arch liners using a utility knife.

Dry test fit the wheel arch liner on the car beforehand and double check that the cut line will give enough clearance (around 10-20mm) to the back flange of the side underpanel.

TOOLS REQUIRED

Utility knife

FASTENERS



- 231. Re-fit the trimmed wheel arch liners, and mudflaps, in reverse order to removal.
- 232. The fitment is now complete. Double check all fasteners are done up and torqued correctly.

TOOLS REQUIRED

8mm socket/spanner

FASTENERS

11x 8mm hex bolt
5x Christmas tree clips

Each side

Retained



Congratulations! You're done! Get out and explore in your good looking and tough RAM 1500!